

APC, April 19th, 2017



DAMIC

The DAMIC experiment: searching for WIMPs and beyond with CCDs

Paolo Privitera



The Enrico Fermi Institute



(Photo image: particle tracks in a DAMIC CCD)

Dark Matter WIMPs 101

1)

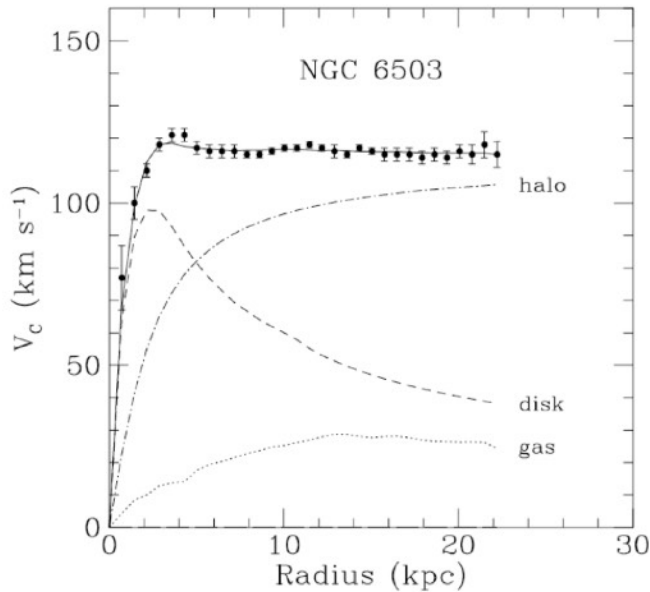

Mass and energy in the Universe

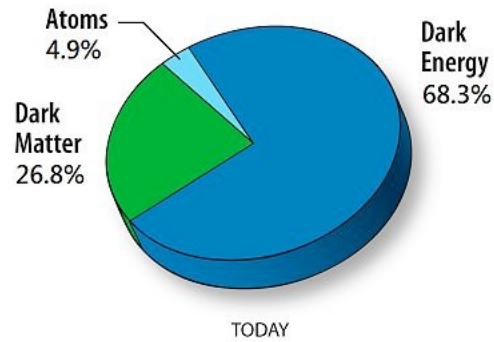

$$\rho_{DM} \approx 0.3 \text{ GeV/cm}^3$$

Astrophysical evidence for DM:
Galaxy rotation curve, lensing, CMB

2) WIMP “miracle”:
a Weakly Interacting Massive Particle
in thermal equilibrium with SM particles
in the early universe. To give the
observed DM density, interactions and
masses must be close to weak-scale

$$\langle \sigma v \rangle \approx 3 \times 10^{-26} \text{ cm}^3/\text{s} \approx 1 / (20 \text{ TeV})^2$$

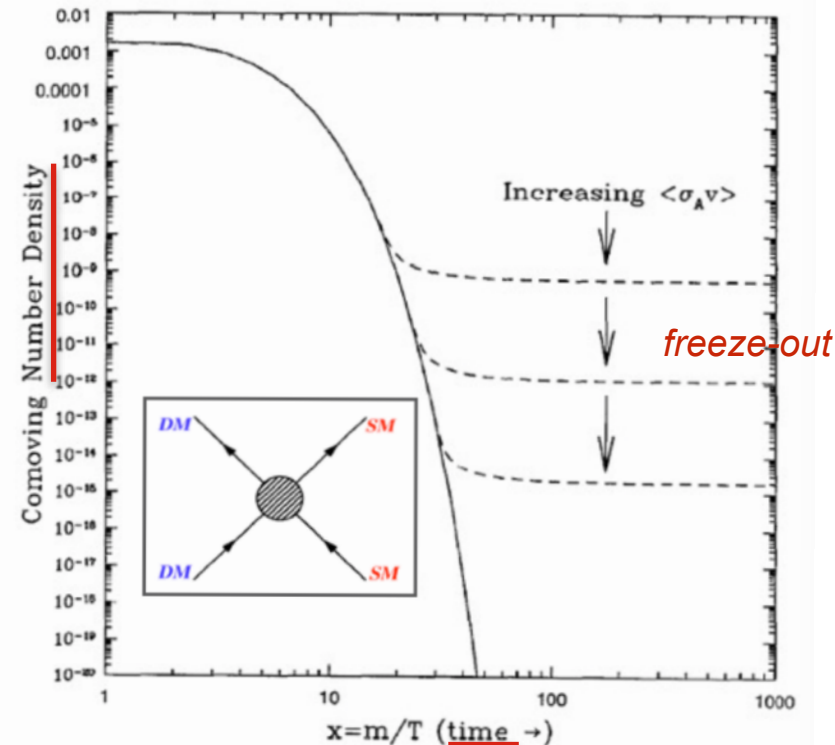

3) Milky Way motion

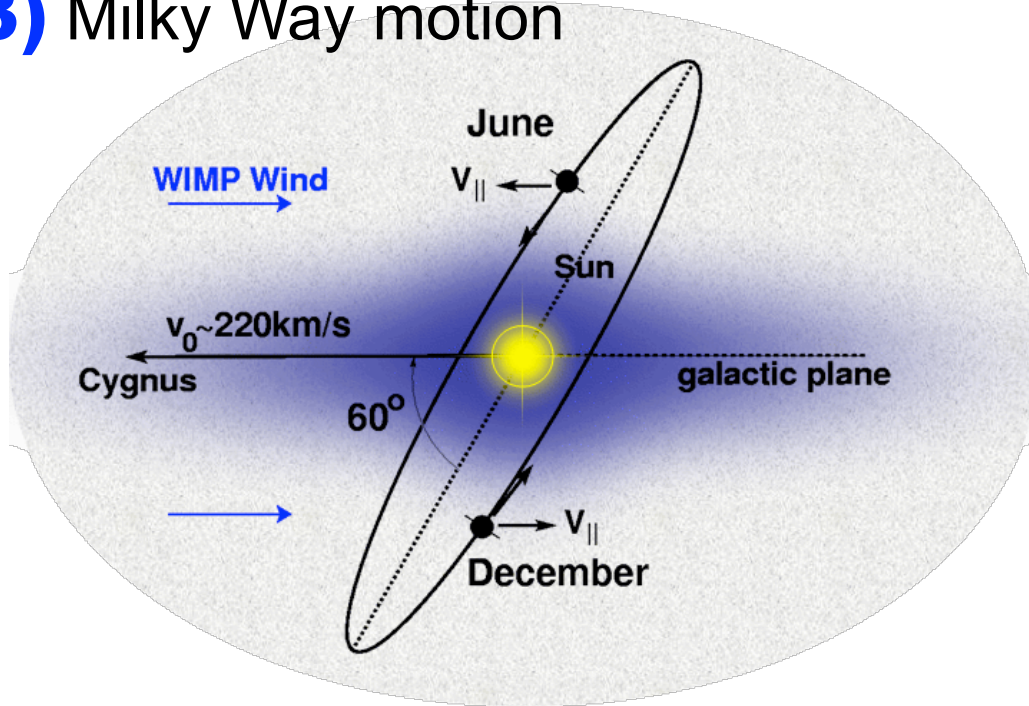

4) WIMP kinetic energy in the Earth (detector) frame

$$\frac{1}{2} m_{\chi} v_0^2 \approx 30 \text{ keV}$$

$$(m_{\chi} = 100 \text{ GeV})$$

Low energy interaction with matter

$$v_0 \approx 10^{-3} c$$

5) Coherent elastic scattering

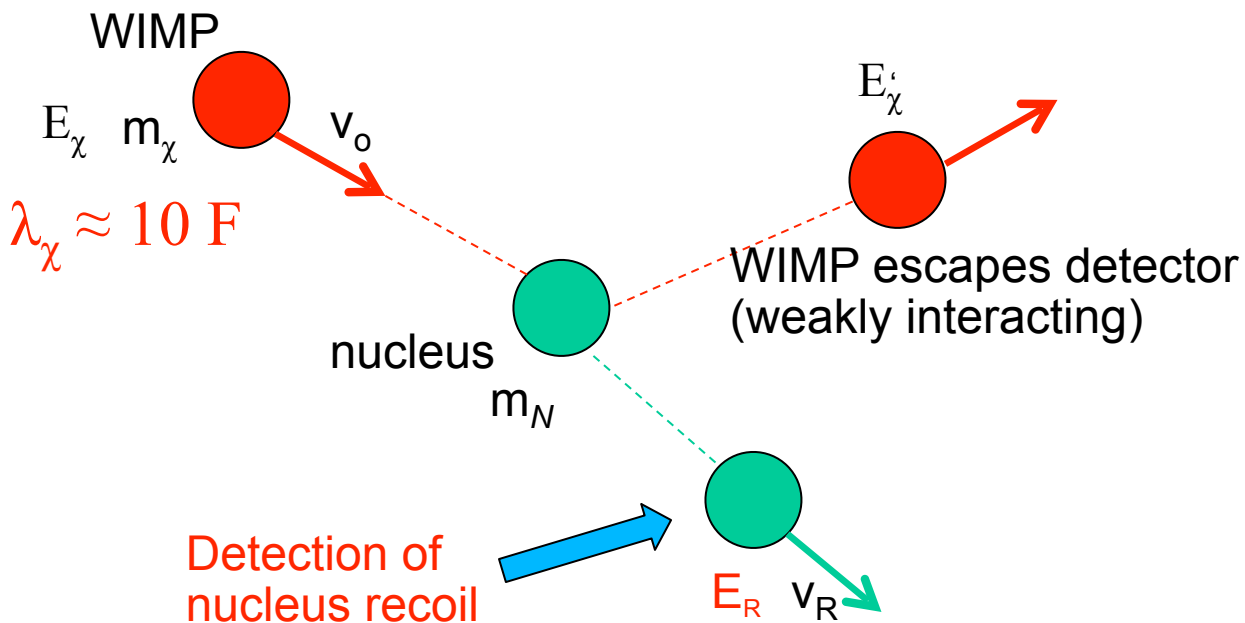

6)

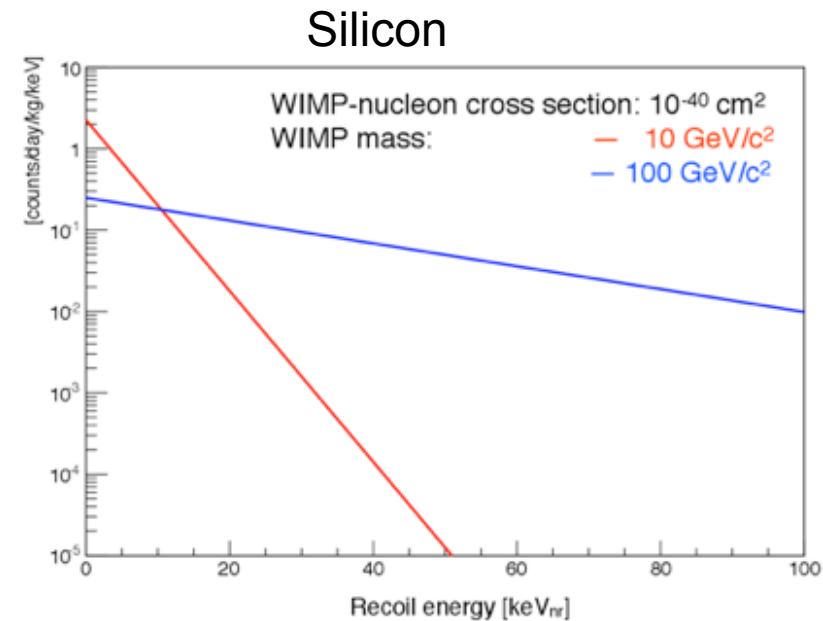

Experimental challenges

- Massive target-detector
- Ultra-pure target (radioactive contaminants)
- Low energy threshold (tens of keV vs MeV in neutrino physics)
- Low background (deep underground; material screening and selection)

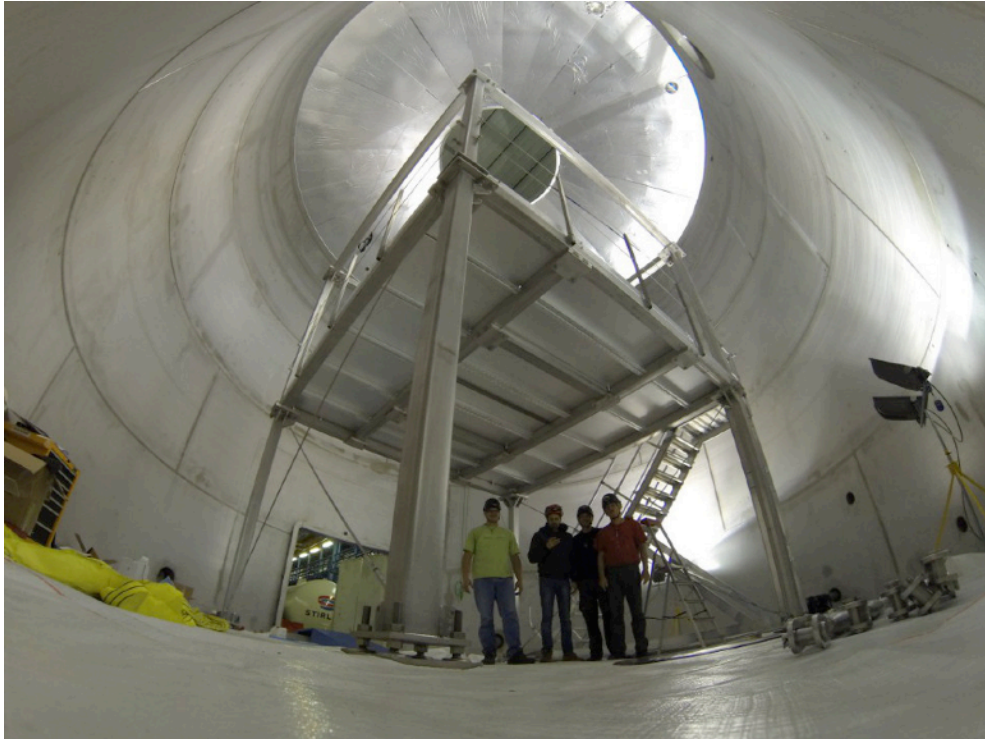

Cryostat support in the Veto water tank

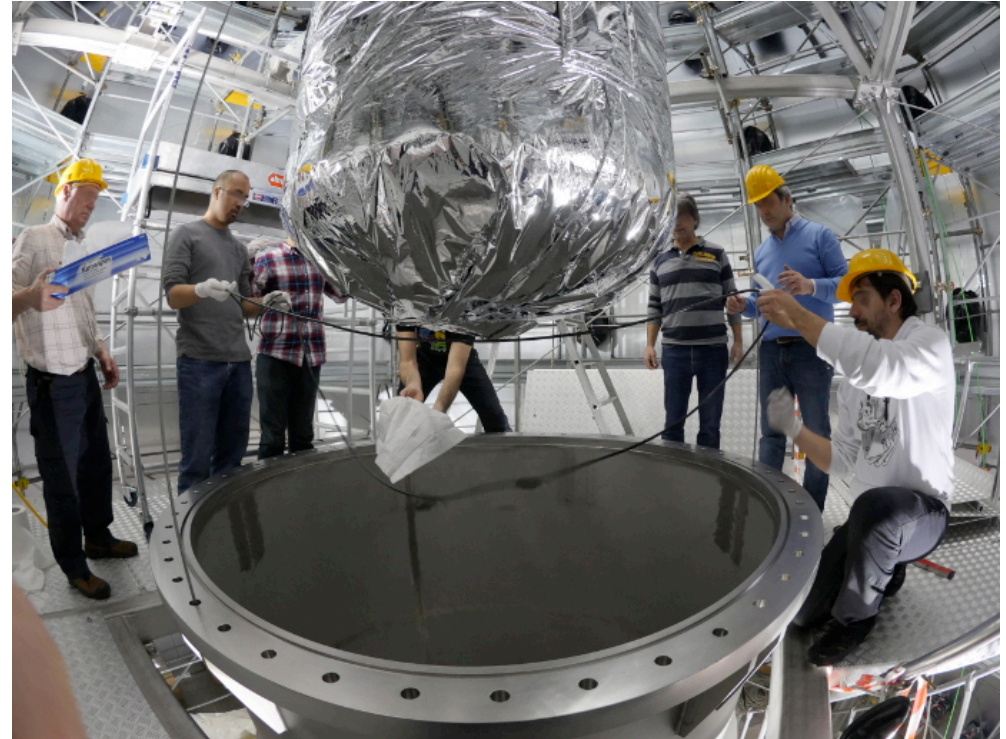

Xenon 1T

Cryostat

7) Nuclear recoil ionization efficiency (quenching factor)



Take a nucleus and an electron of the same energy ($E_R = E_e$).

In general, $E_{\text{det}}^R < E_{\text{det}}^e$ (the nucleus dissipates its energy through mechanisms other than ionization) “Lindhard theory”

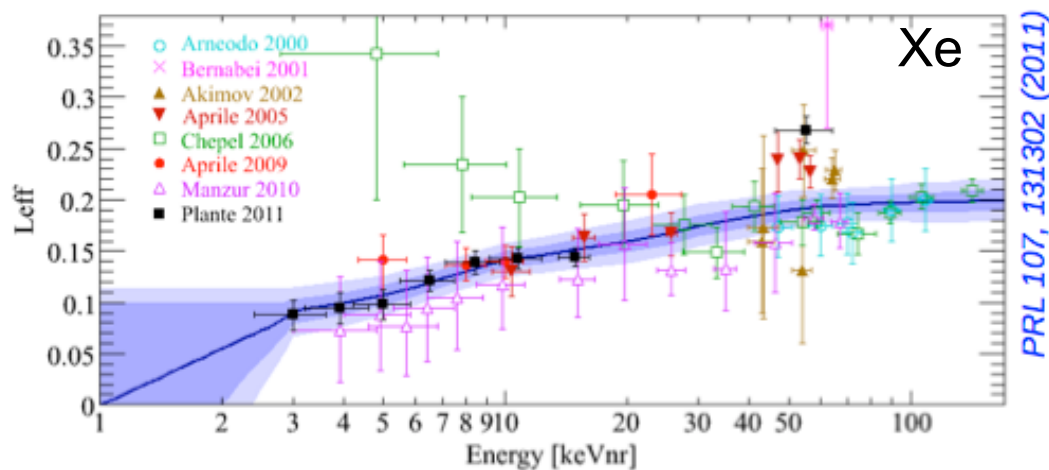

For a given detector (“electron”) energy threshold, the nuclear recoil energy threshold depends on the QF. Essential to measure.

WIMP exclusion plot

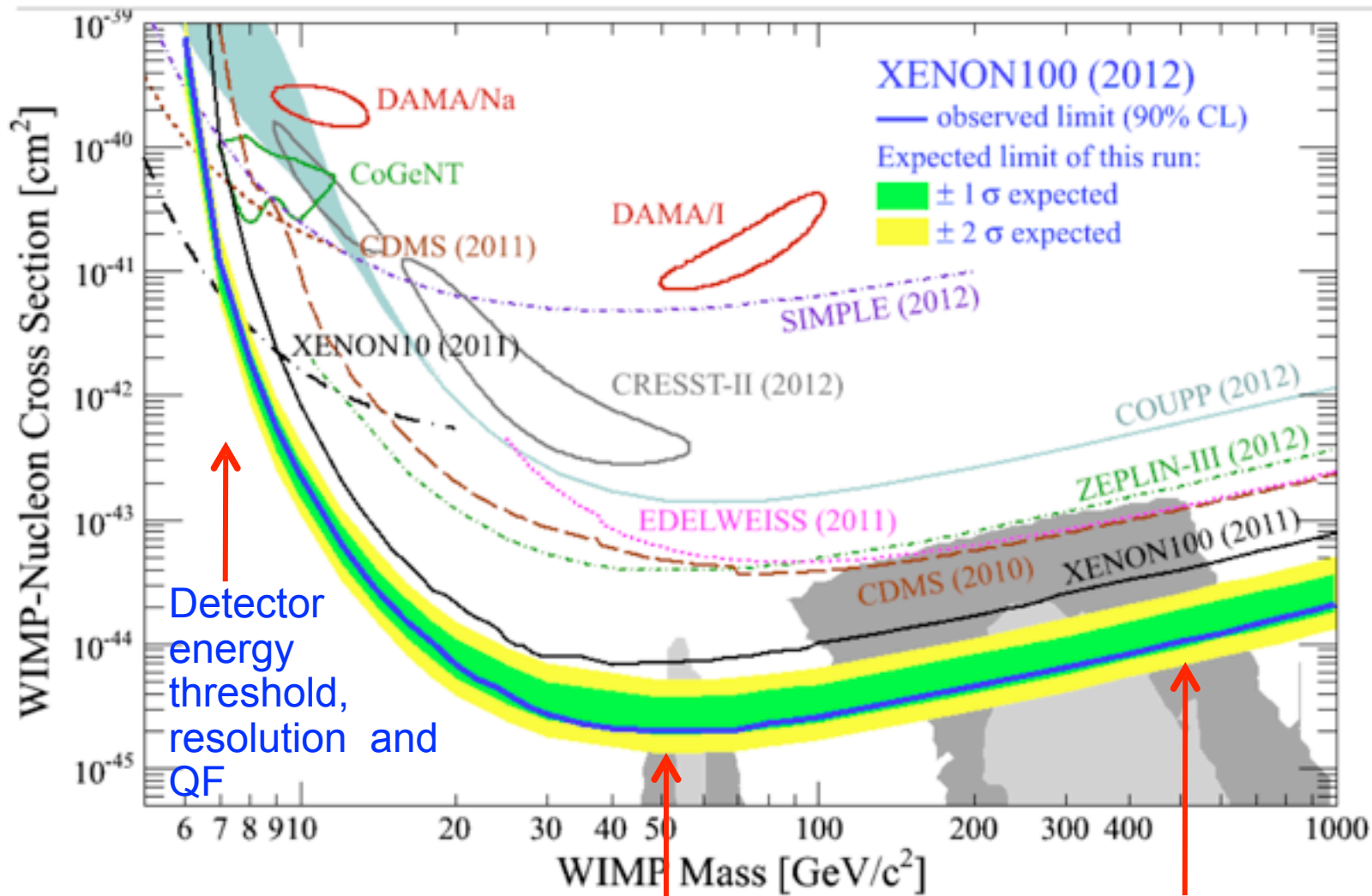

$$E_R \approx E_\chi \cdot r \quad E_\chi = 0.5 m_\chi v^2$$

$$r = \frac{4m_\chi m_N}{(m_\chi + m_N)^2}$$

$$m_\chi \approx m_N$$

$$n \sim \rho/m_\chi$$

$$E_R \approx 0.5 m_N v^2$$

Next generation WIMP frontier

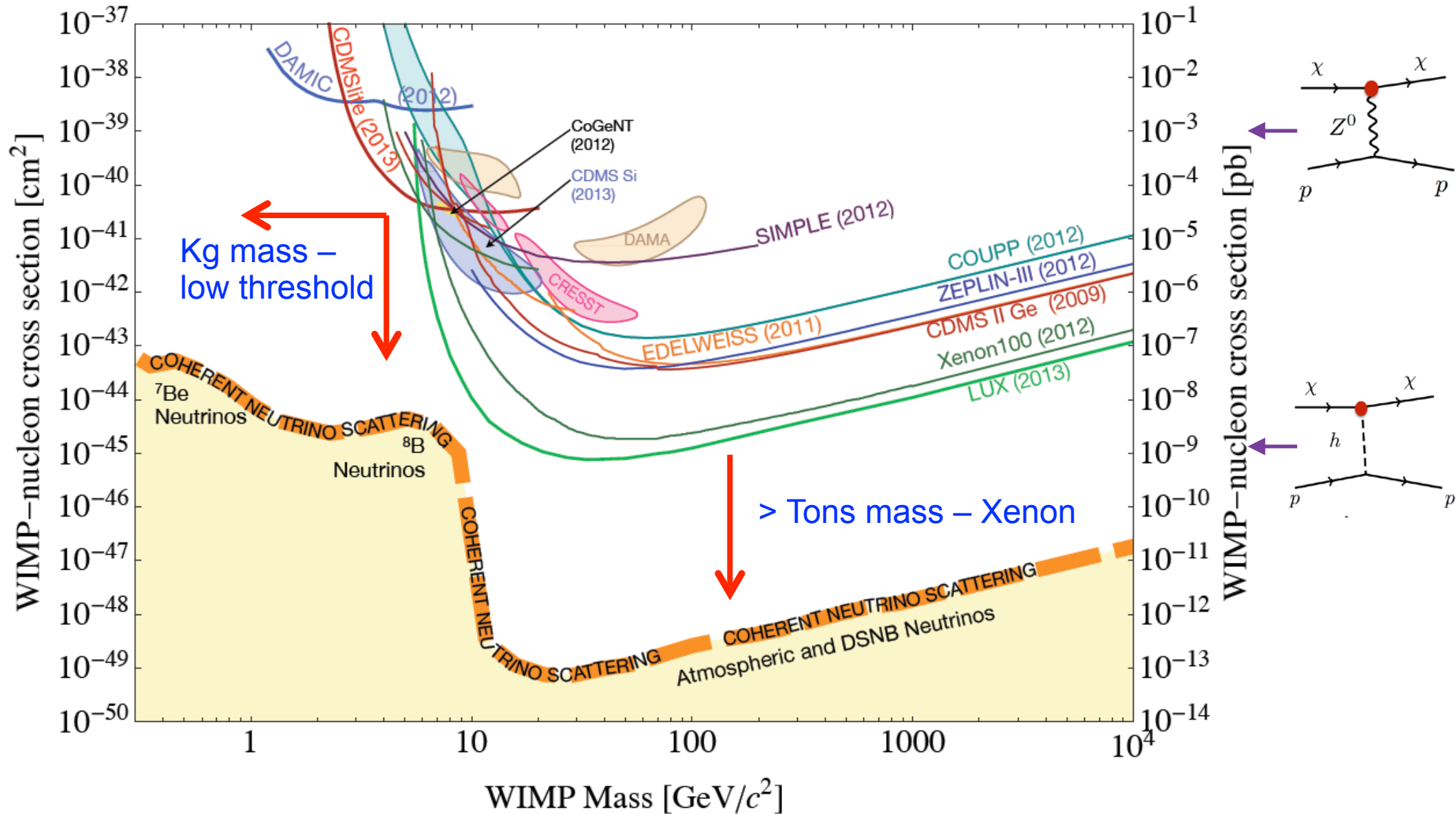

Beyond the WIMP paradigm

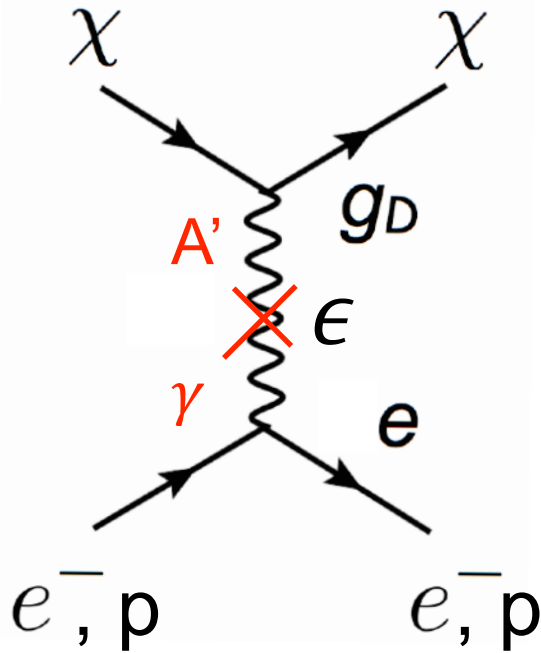

- “Dark QED” models

kinetically mixed hidden photon A' $\epsilon e A'_\mu J_{EM}^\mu$

$$\bar{\sigma}_e \approx \alpha \epsilon^2 \alpha_D \times \text{kinematic terms}$$

- A rich, unexplored DM phenomenology :
 A' massive or light, χ (elastic) scalar, Dirac fermion; (inelastic) scalar, Majorana fermion

- Nuclear recoils

$$m_\chi \approx \text{few GeV}$$

$$E_R = \frac{1}{2} m_\chi^2 v_o^2$$

$$\approx 1 \text{ keV}_{nr}$$

(+ quenching factor)

- Electron recoils:

the e^- (not χ) sets the typical momentum transfer

$$v_e \sim \alpha \gg v_o \sim 10^{-3} \quad (\text{outer shell electron})$$

$$q_{\text{typ}} \simeq \mu_{\chi e} v_{\text{rel}} \sim \alpha m_e \sim 4 \text{ keV}$$

(does not depend on m_χ , can explore MeV DM masses!) 8

light A' ($m_{A'} \approx m_\chi$)

ultra-light A'

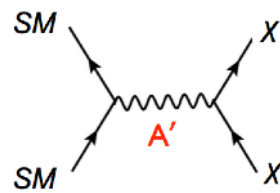
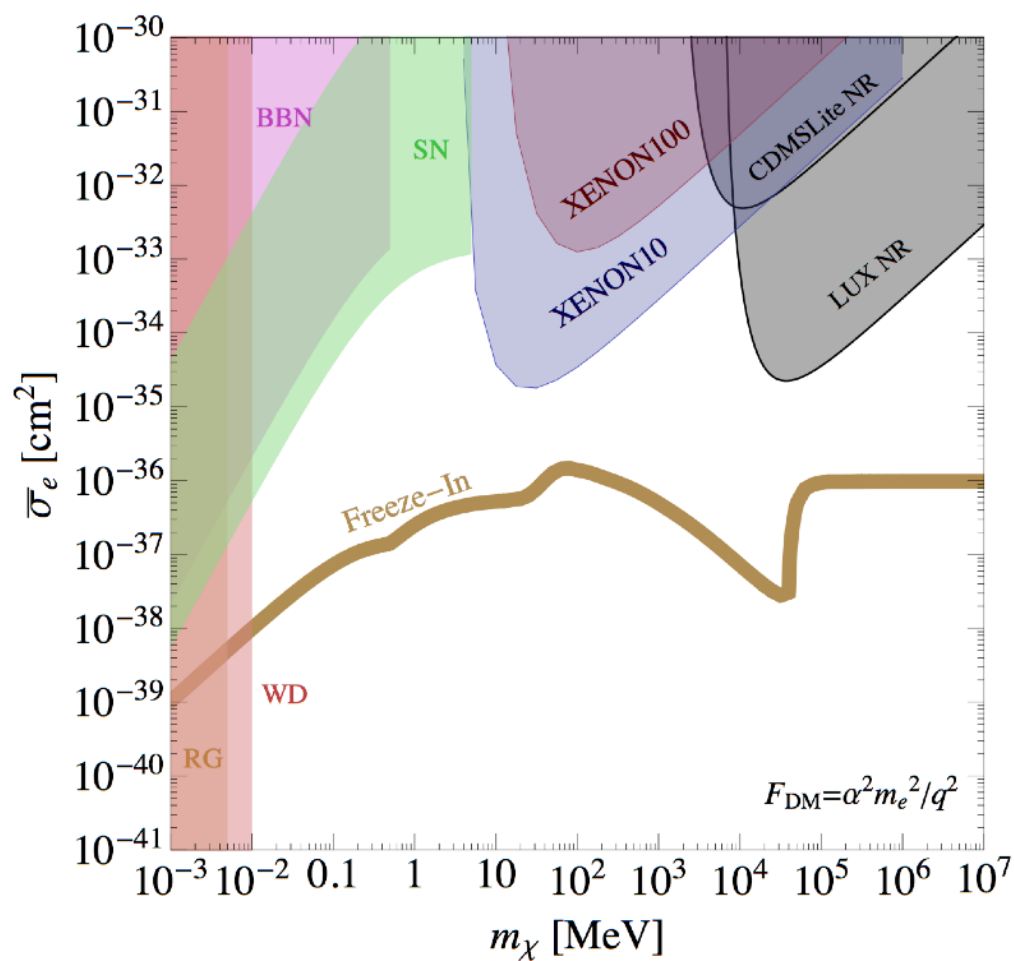
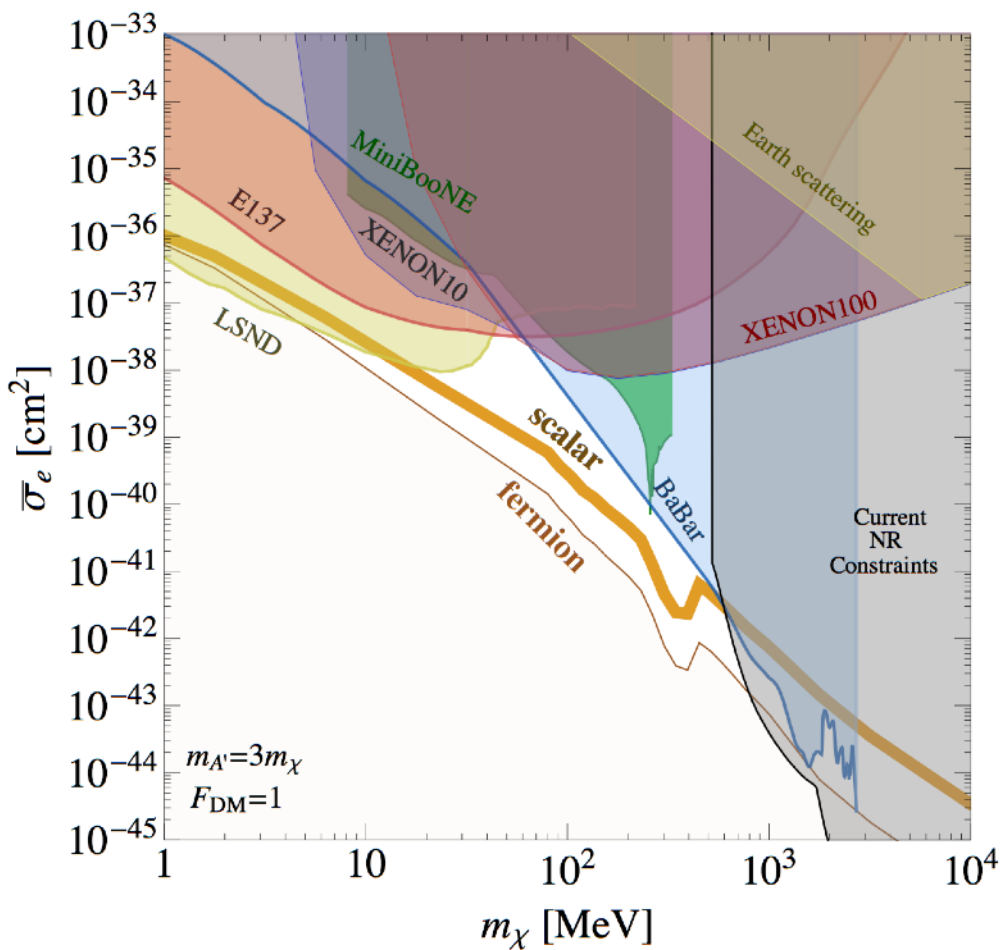

freeze-in from thermal SM bath

Charge-Coupled-Devices



Dark Energy Survey Camera

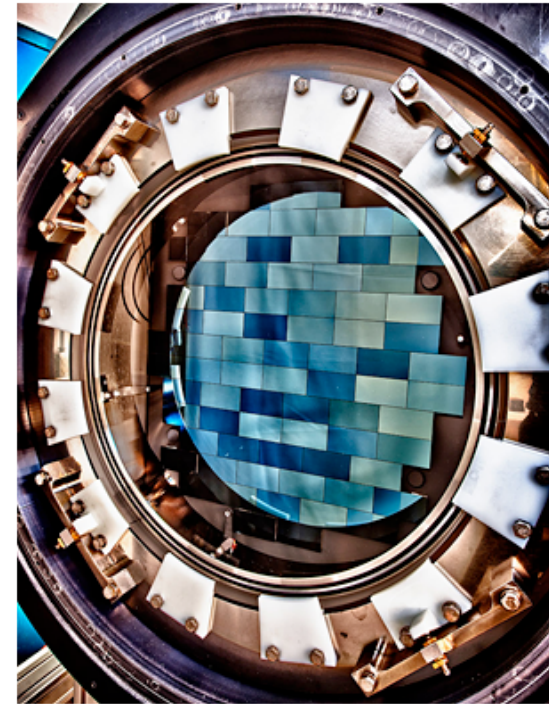

250 μm thick CCDs with enhanced IR sensitivity developed at LBNL

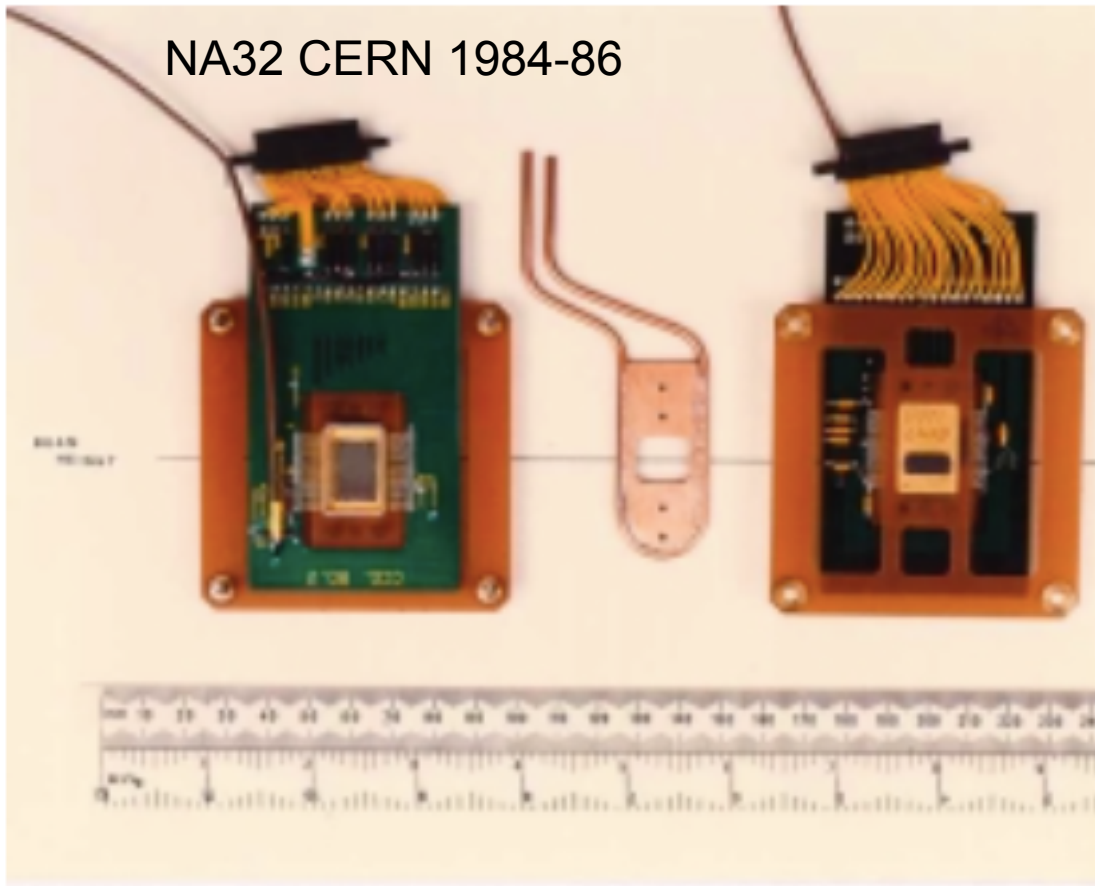

COSMIC RAYS AND OTHER NONSENSE IN ASTRONOMICAL CCD IMAGERS

DON GROOM

Lawrence Berkeley National Laboratory

(Accepted 23 July 2003)

DAMIC enabled by

Abstract. Cosmic-ray muons make recognizable straight tracks in the new-generation CCD's with thick sensitive regions. Wandering tracks ('worms'), which we identify with multiply-scattered low-energy electrons, are readily recognized as different from the muon tracks. These appear to be mostly recoils from Compton-scattered gamma rays, although worms are also produced directly by beta emitters in dewar windows and field lenses. The gamma rays are mostly byproducts of ^{40}K decay and the U and Th decay chains. Trace amounts of these elements are nearly always present in concrete and other materials. The direct betas can be eliminated and the Compton recoils can be reduced significantly by the judicious choice of materials and shielding. The cosmic-ray muon rate is irreducible. Our conclusions are supported by tests at the Lawrence Berkeley National Laboratory low-level counting facilities in Berkeley and 180 m underground at Oroville, California.

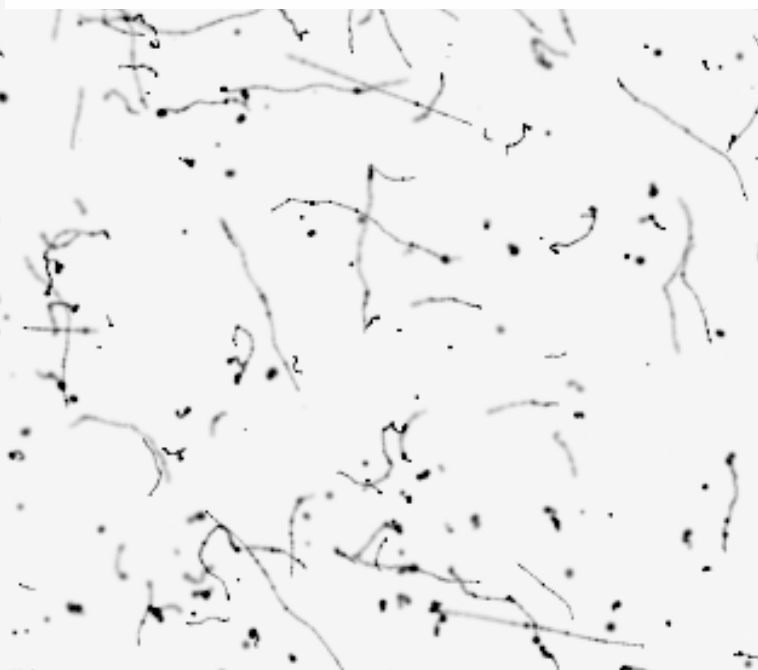

How a CCD works

Metal-Oxide-Semiconductor capacitor

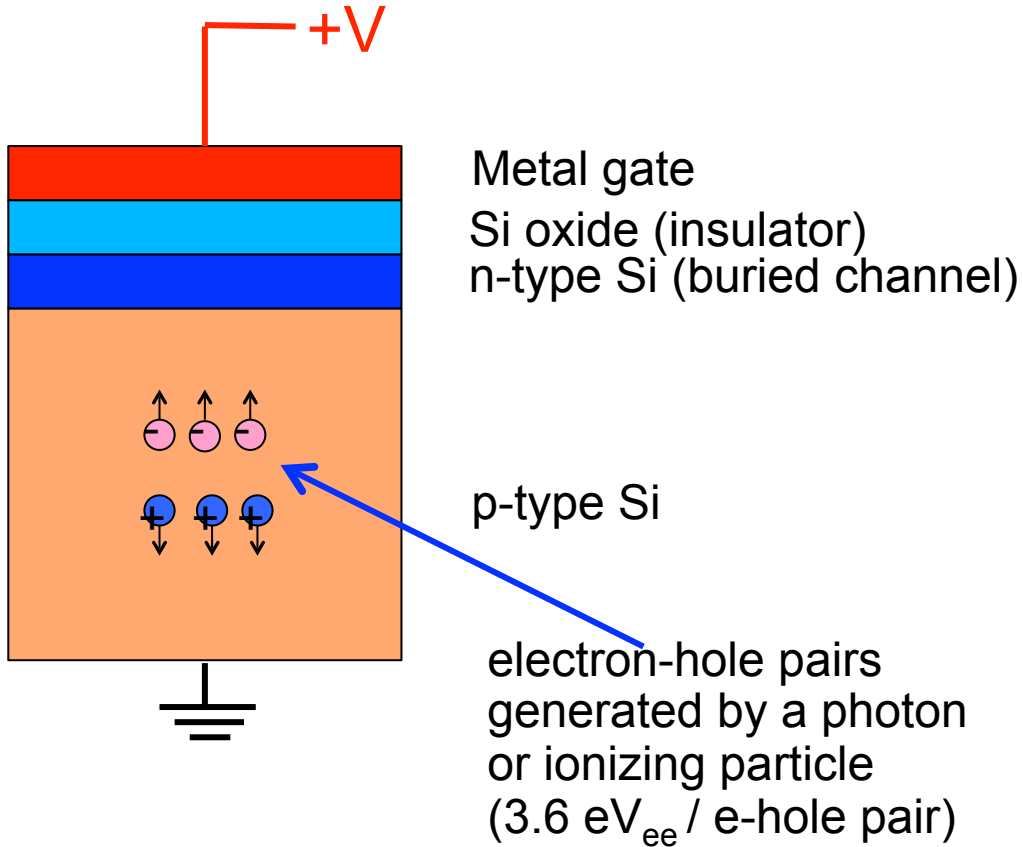

A CCD is an array of MOS capacitors

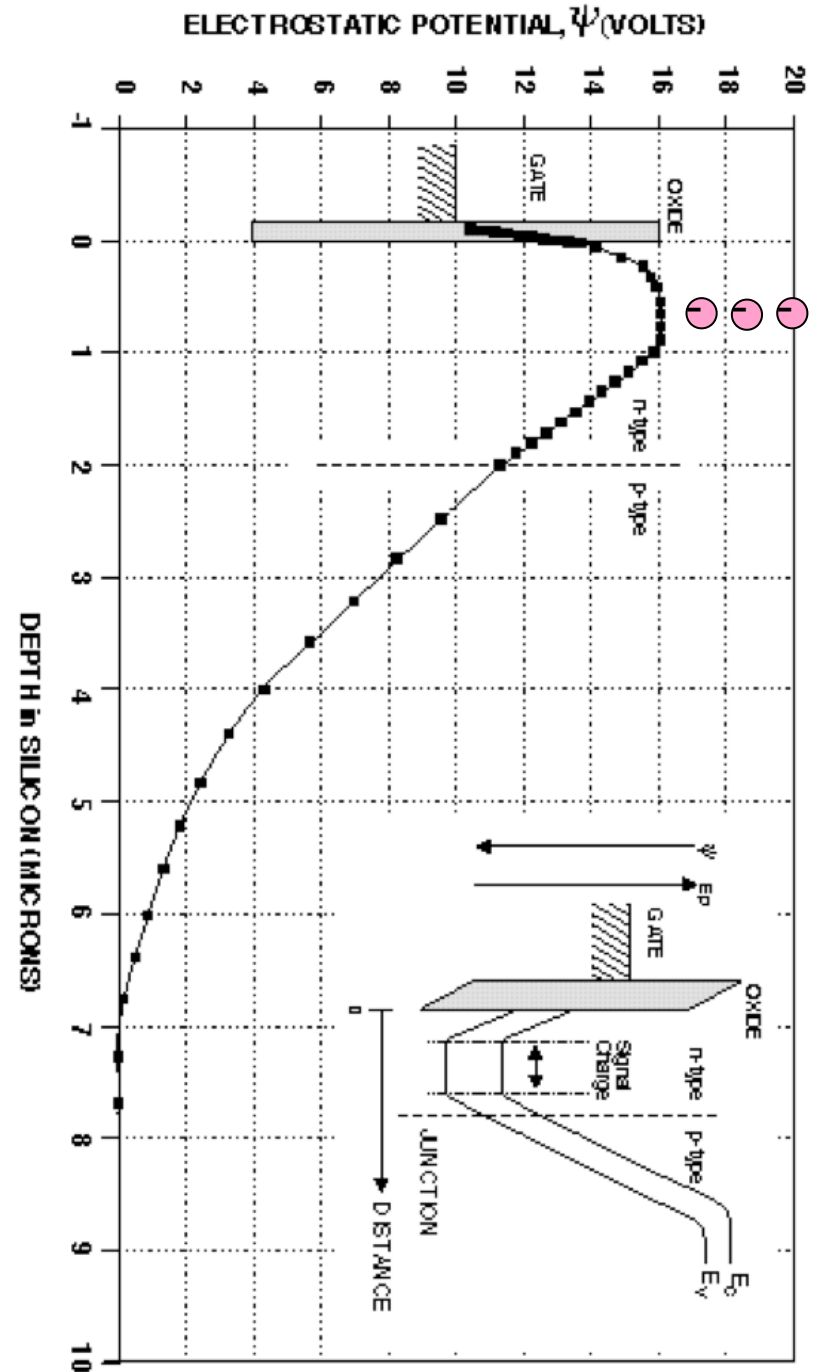

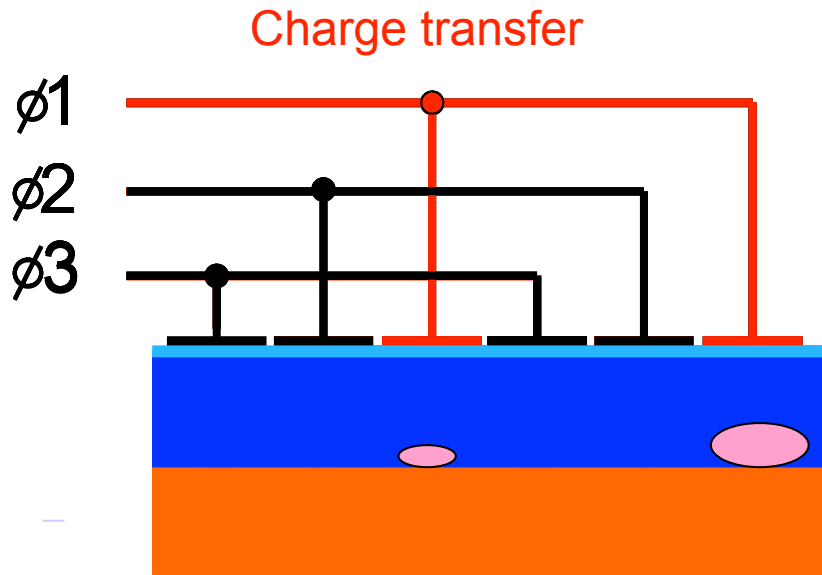
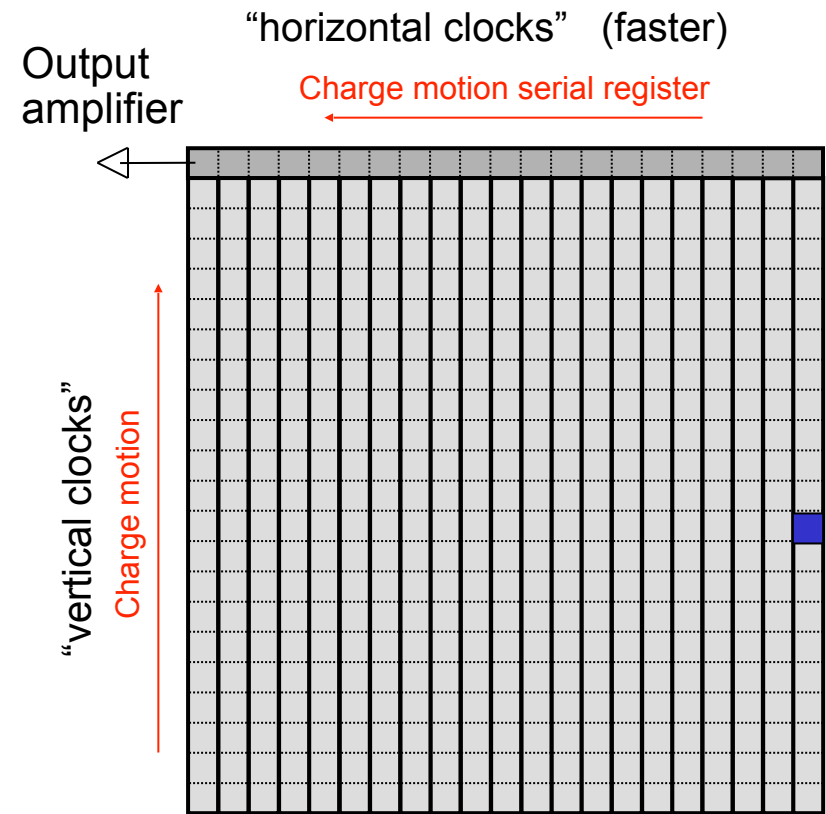
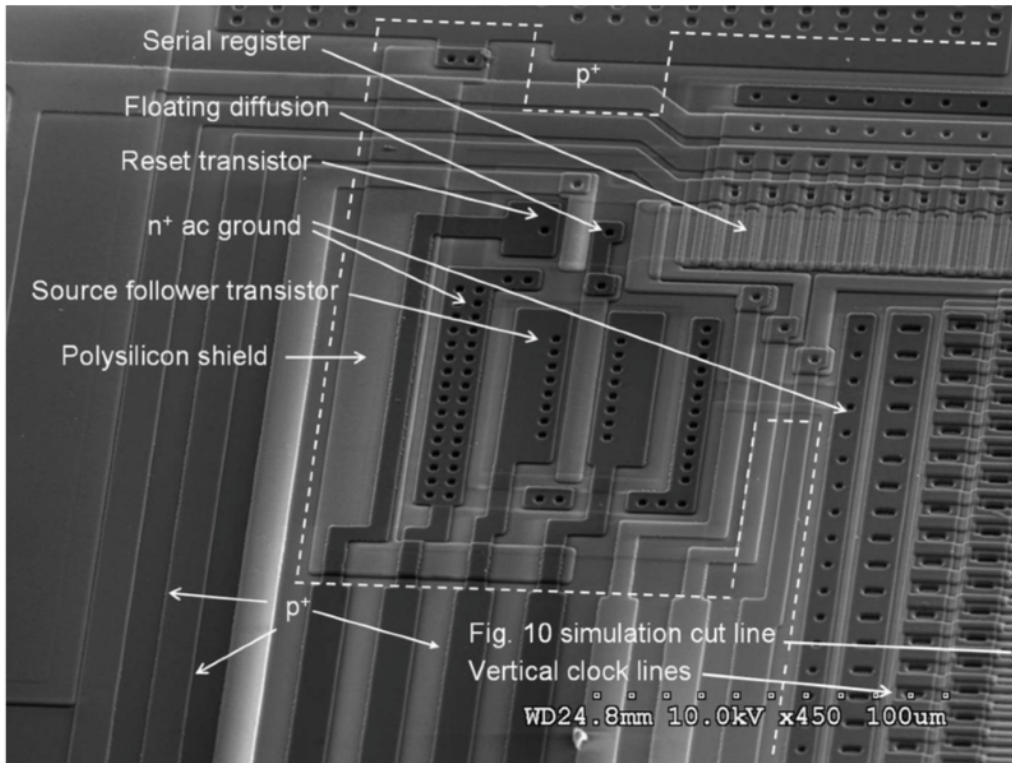

CCD in action

CCD pixel charge readout

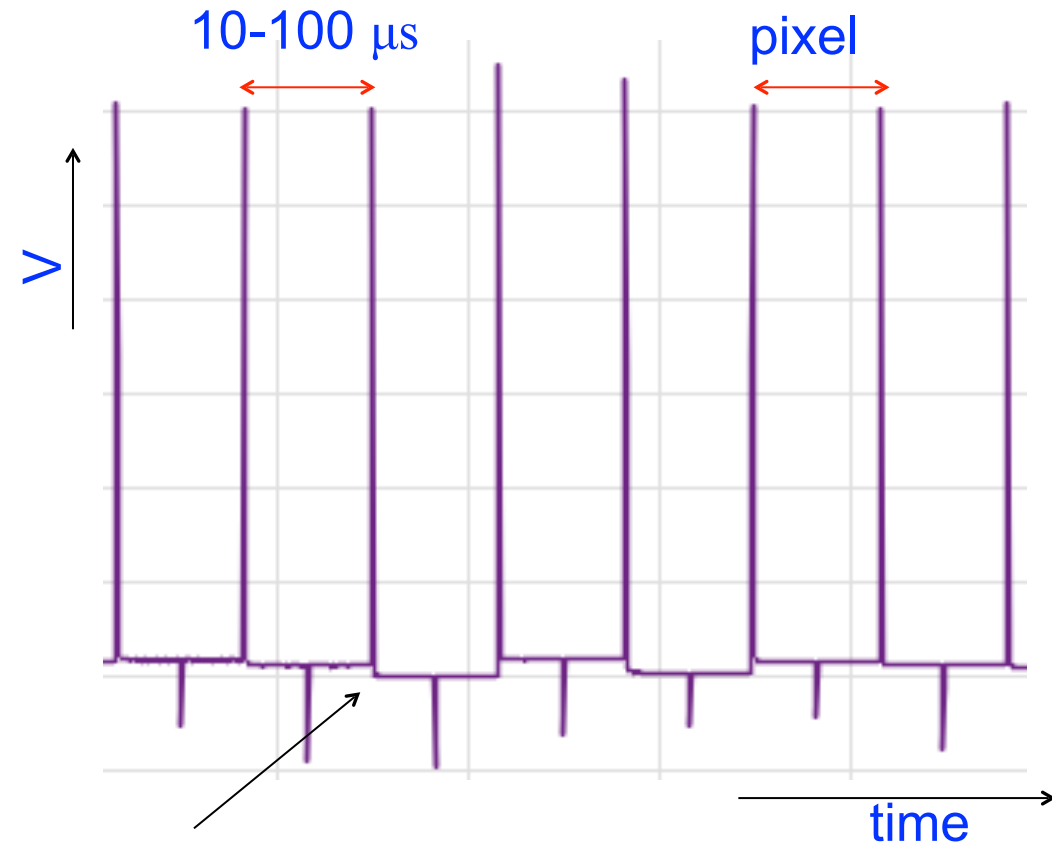
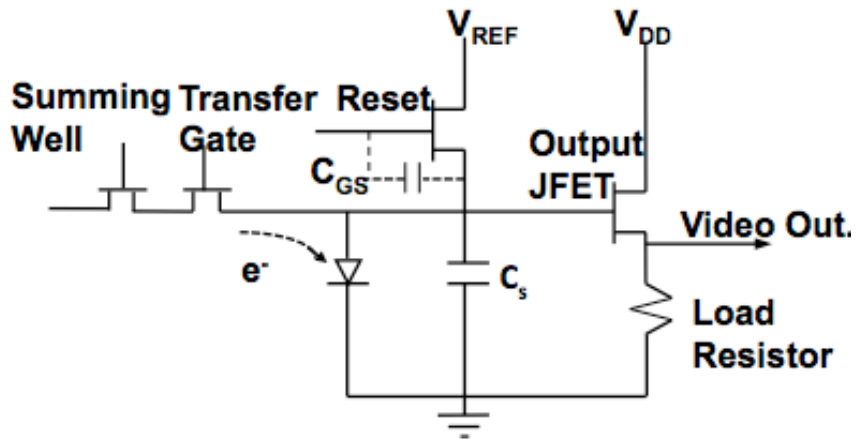

Reset pulse
(inject noise charge)

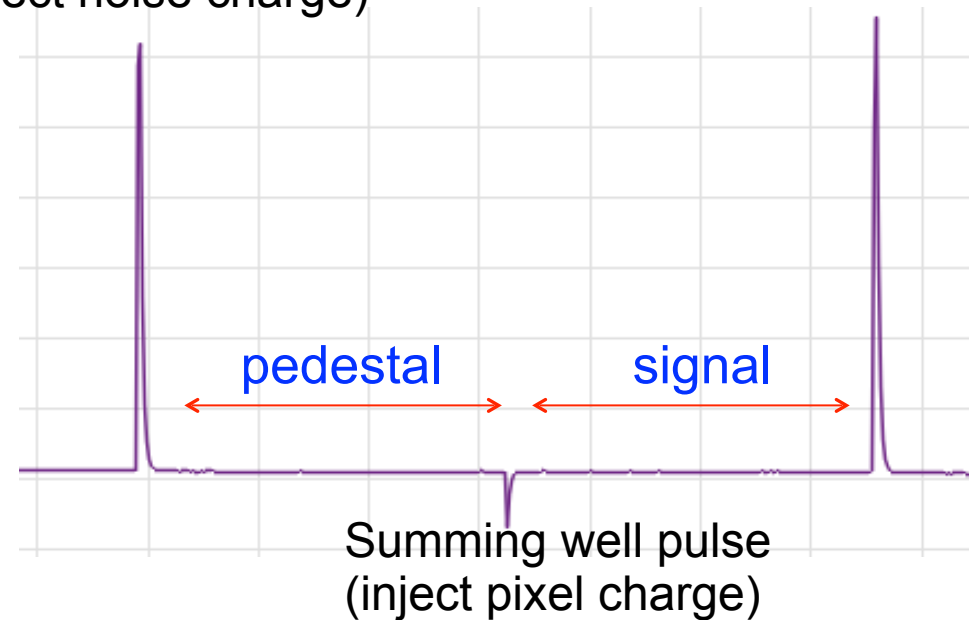

Correlated Double Sampling (CDS)

(signal – pedestal) cancels the reset noise (and also other correlated noise)

Performed analogically in standard CCD readouts

Why Dark Matter in CCDs ?

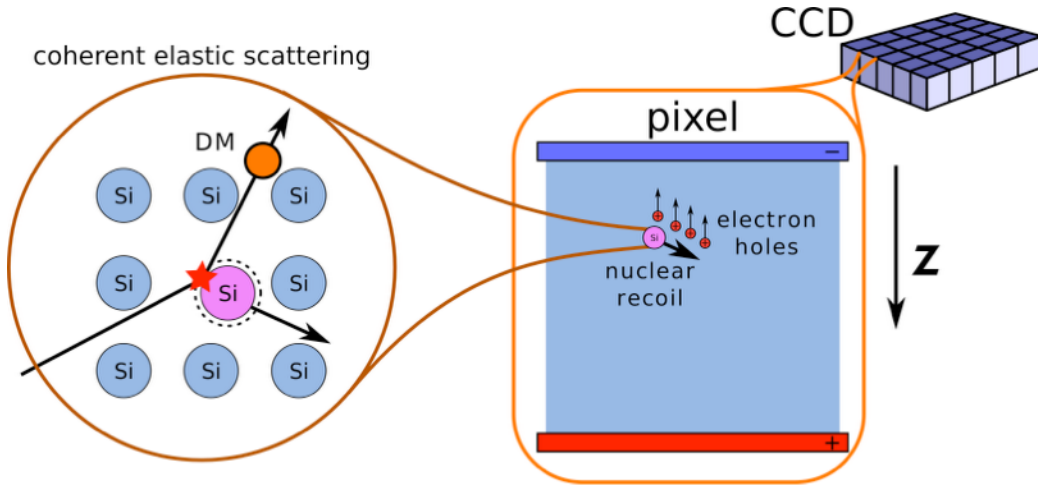

- Detection of point-like energy deposits from nuclear recoils induced by WIMP interactions (10 keV Si ion range 200 Å)

1) High-resistivity (10^{11} donors/cm³)
extremely pure silicon

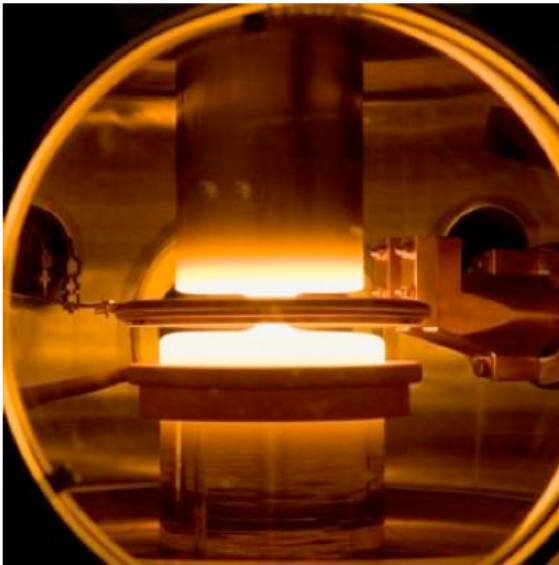

Float-zone Si

2) Fully-depleted over several 100s μm (typical CCDs few tens of μm)

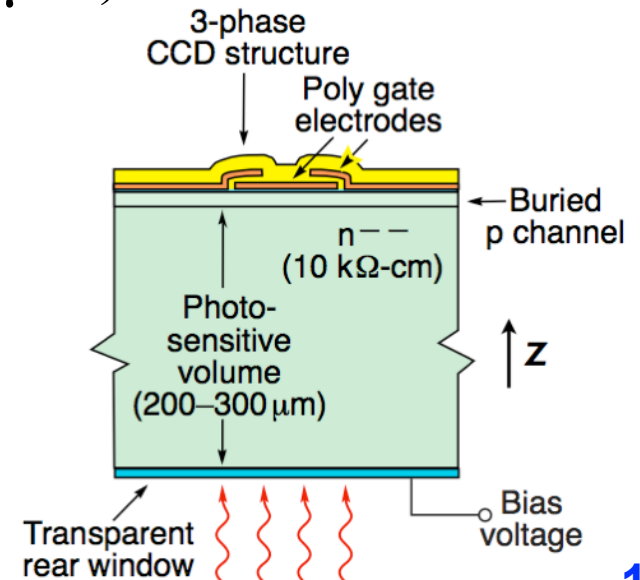

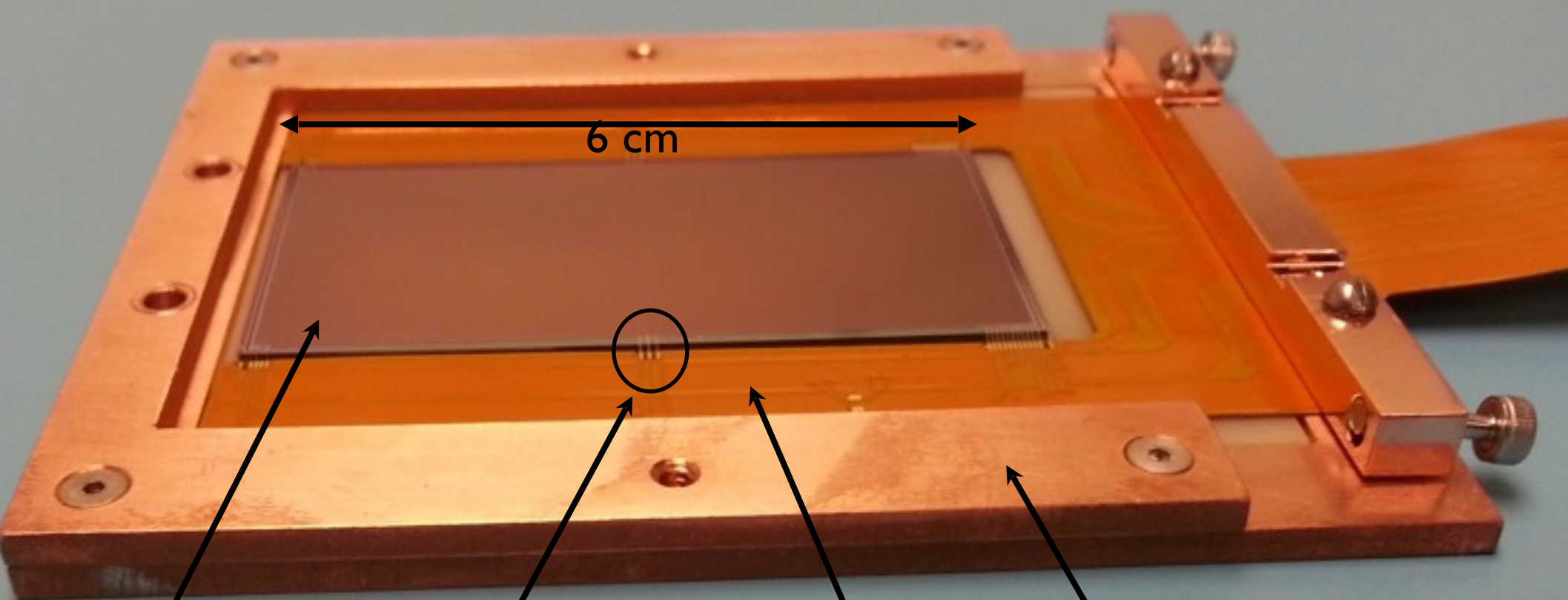

CCD
2k x 4k

Wire bonds

Clocks, Bias,
and Signal cable

Copper frame

3) Sizable mass

First DAMIC CCDs from DECam!

a DAMIC CCD **6 cm x 6 cm**, **16 Mpixel** (**15 μm x 15 μm**) has a record thickness of **675 μm** and **5.9 g** mass

DAMIC100 currently taking data at the SNOLAB underground laboratory

4) Unprecedented low energy threshold

- Negligible noise contribution from dark current fluctuations (dark current < 0.001 e/pixel/day with CCD cooled at 120 K). Readout noise dominant contribution.

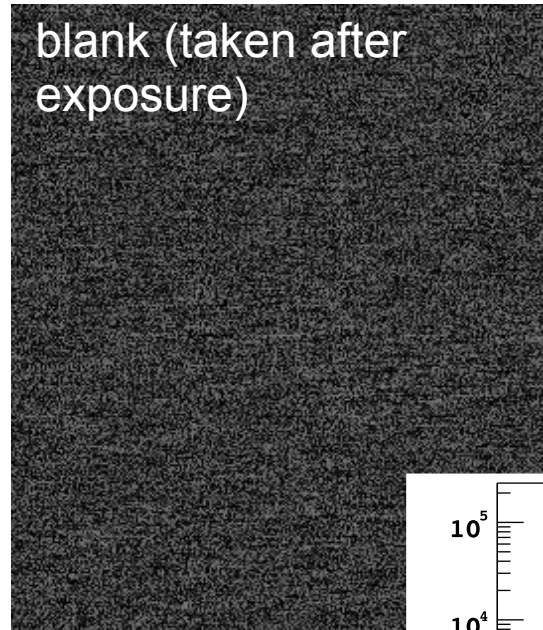
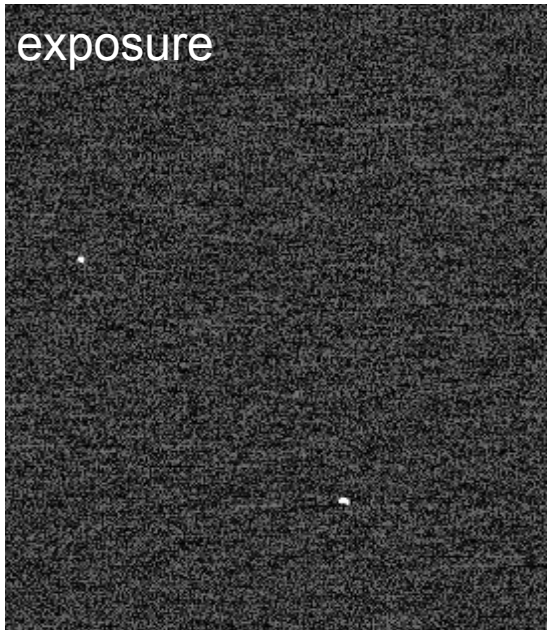

- A readout noise of ≈ 2 e- is achieved by slow CCD readout (≈ 10 min / 16 Mpix image).

3.6 eV to produce 1 e-hole pair

1.2 eV band gap

- Very long exposures (8 hours!) to minimize the n. of noise pixels above the energy threshold

Lower threshold, higher WIMP recoil rate (exponential), small mass detector competitive

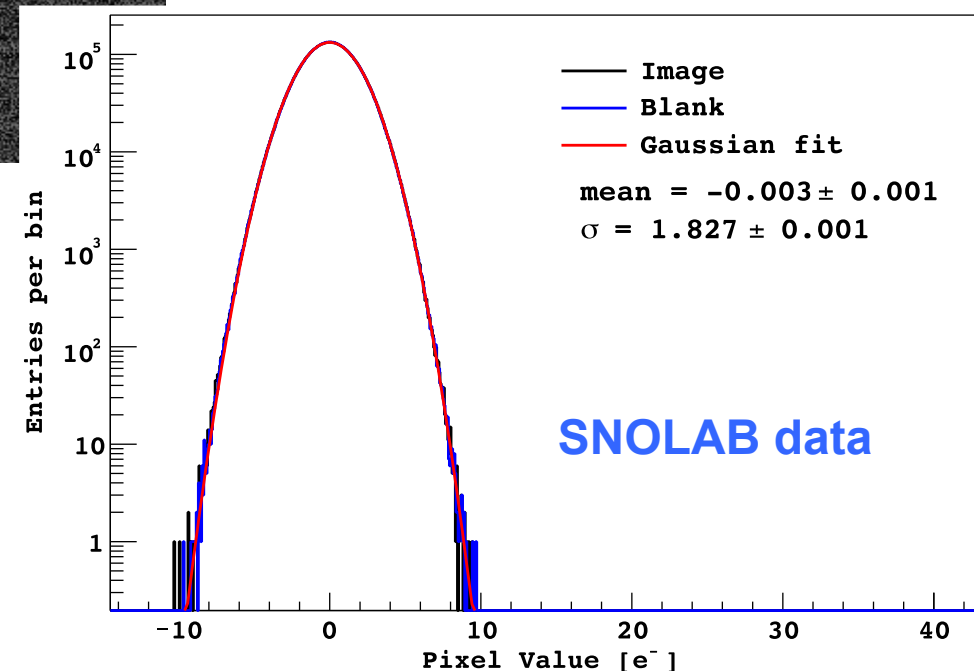

5) Unique spatial resolution: 3D position reconstruction and particle ID

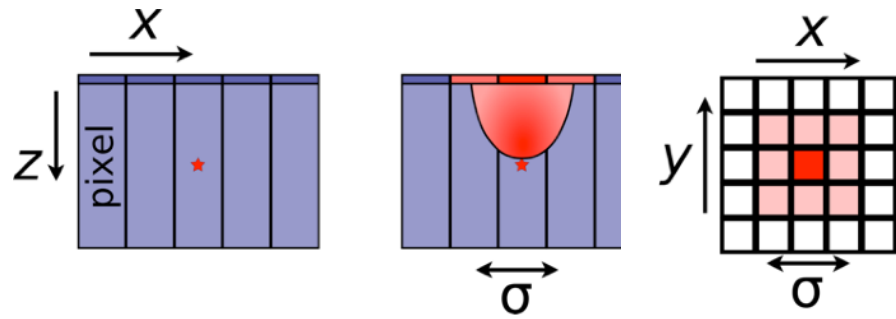

The charge diffuses towards the CCI pixels gates, producing a “diffusion-limited” cluster

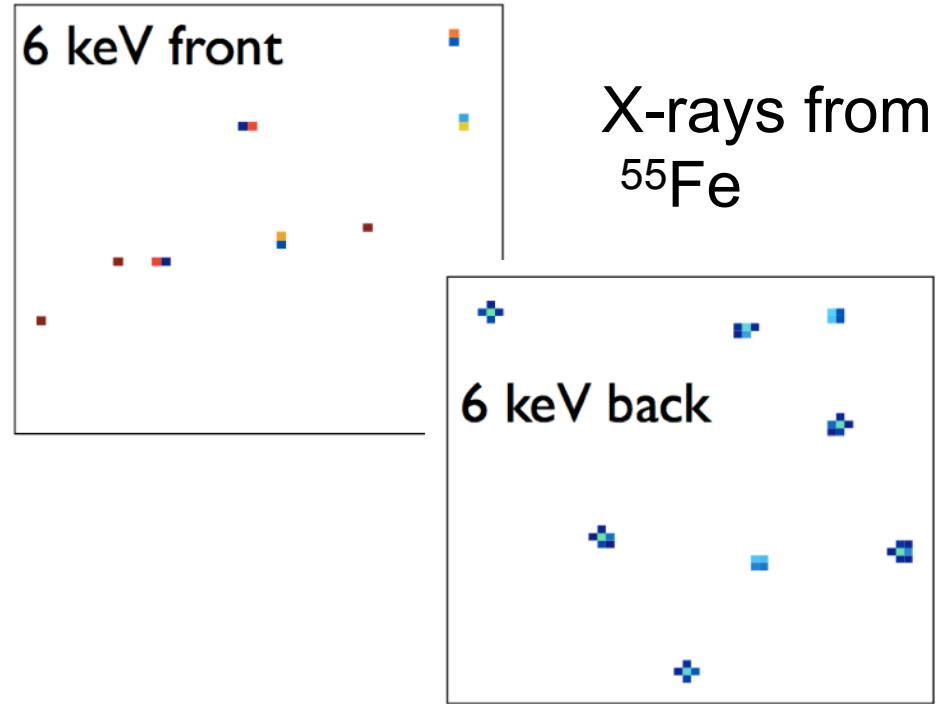

a muon piercing a 675 μm thick DAMIC CCD

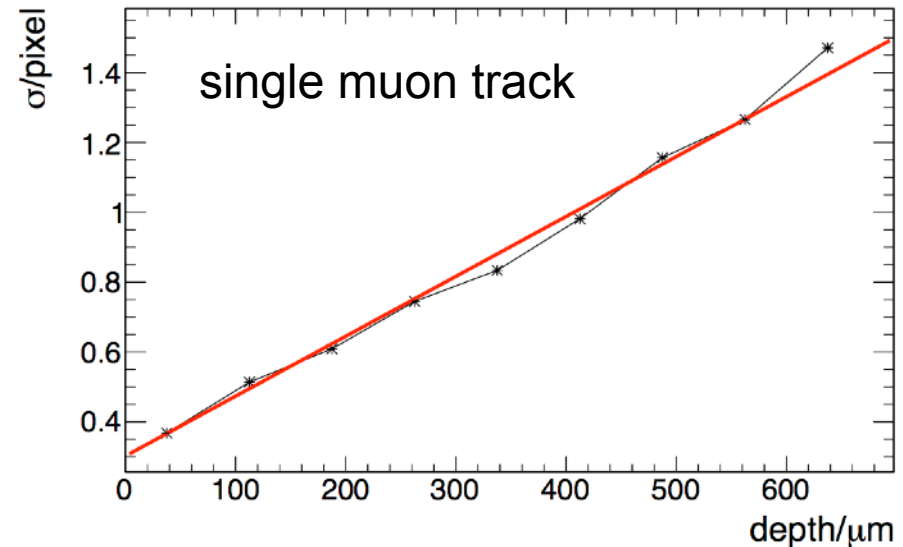
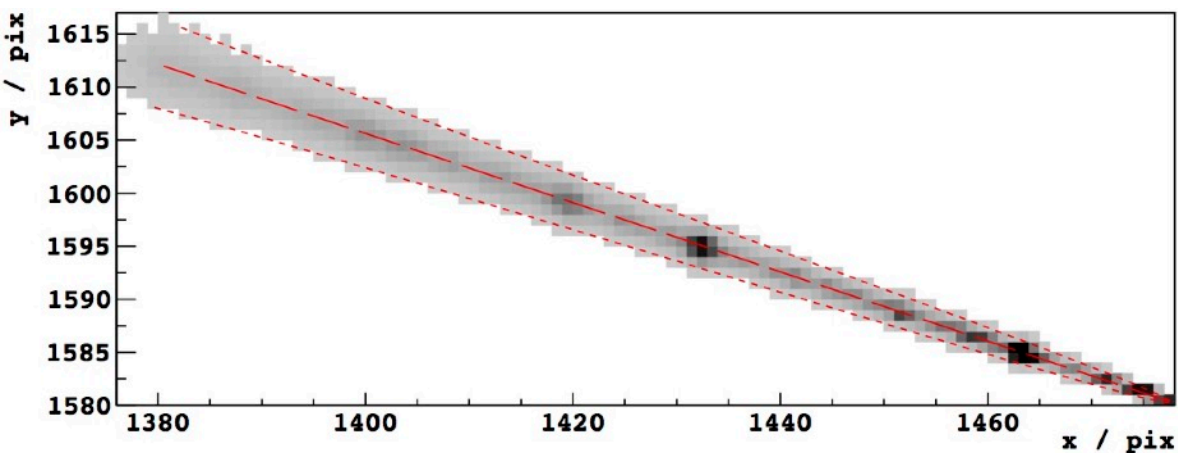

$\sigma \approx Z$: fiducial volume definition and surface event rejection

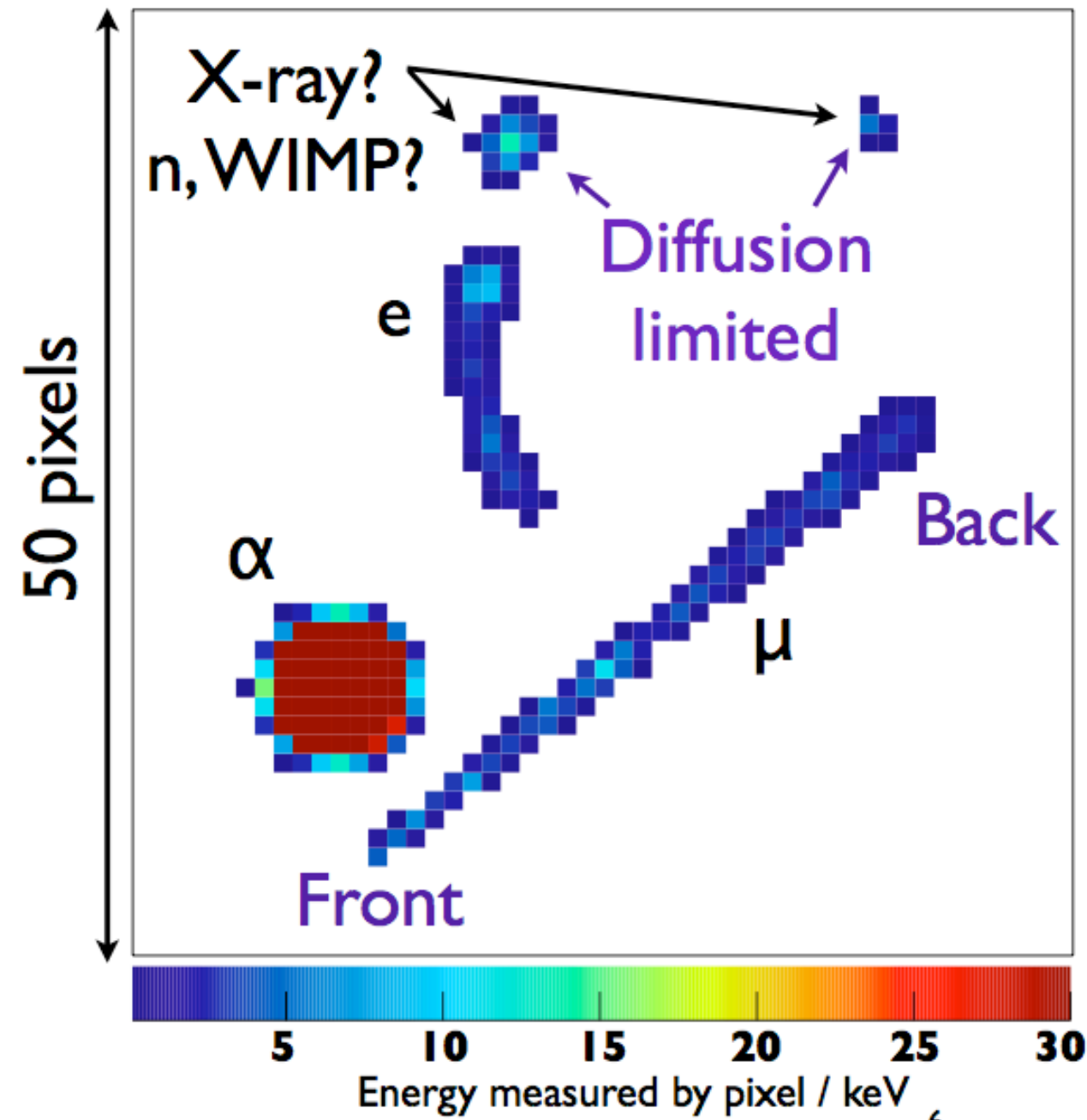

- “Worms” straggling electrons
- Straight tracks: minimum ionizing particles
- MeV charge blobs: alphas
- Diffusion-limited clusters: low-energy X-rays, nuclear recoils
- CCD spatial resolution provides a unique handle to the understanding of the background

SNOLAB

Sudbury, Canada

Nickel-Copper active mine

Creighton Mine #9



in the cage, dropping at 50 km/h



out for a nice walk...

2 km underground

BBC documentary, Dancing in the Dark: the end of Physics



Abandon all hope, ye who enter here Inferno, Canto III, Dante

entering the lab



nice dress!

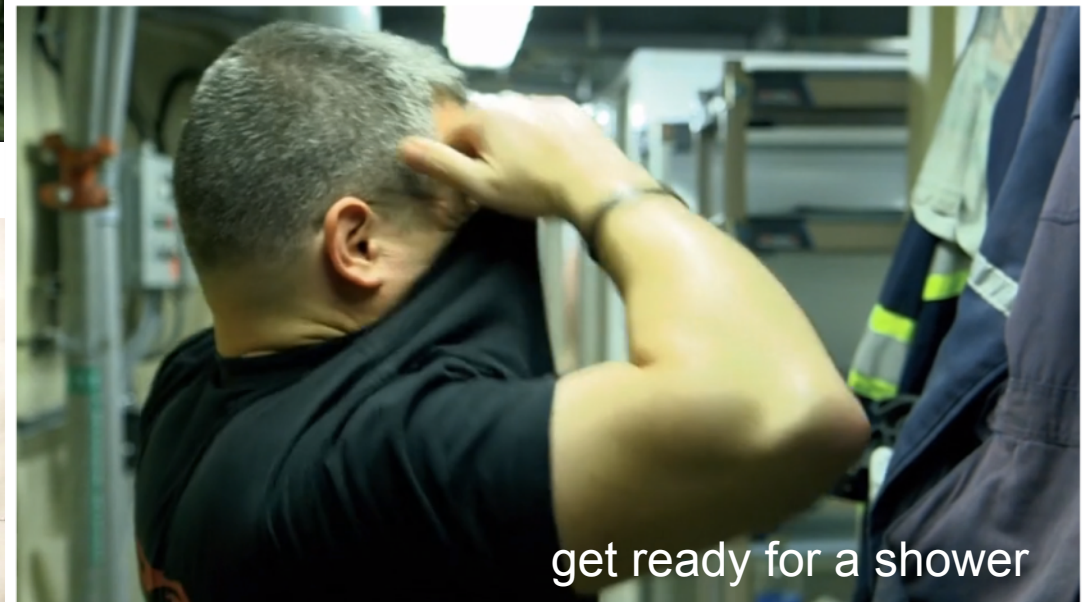

get ready for a shower



coffee.....

Snolab

DAMIC at SNOLAB

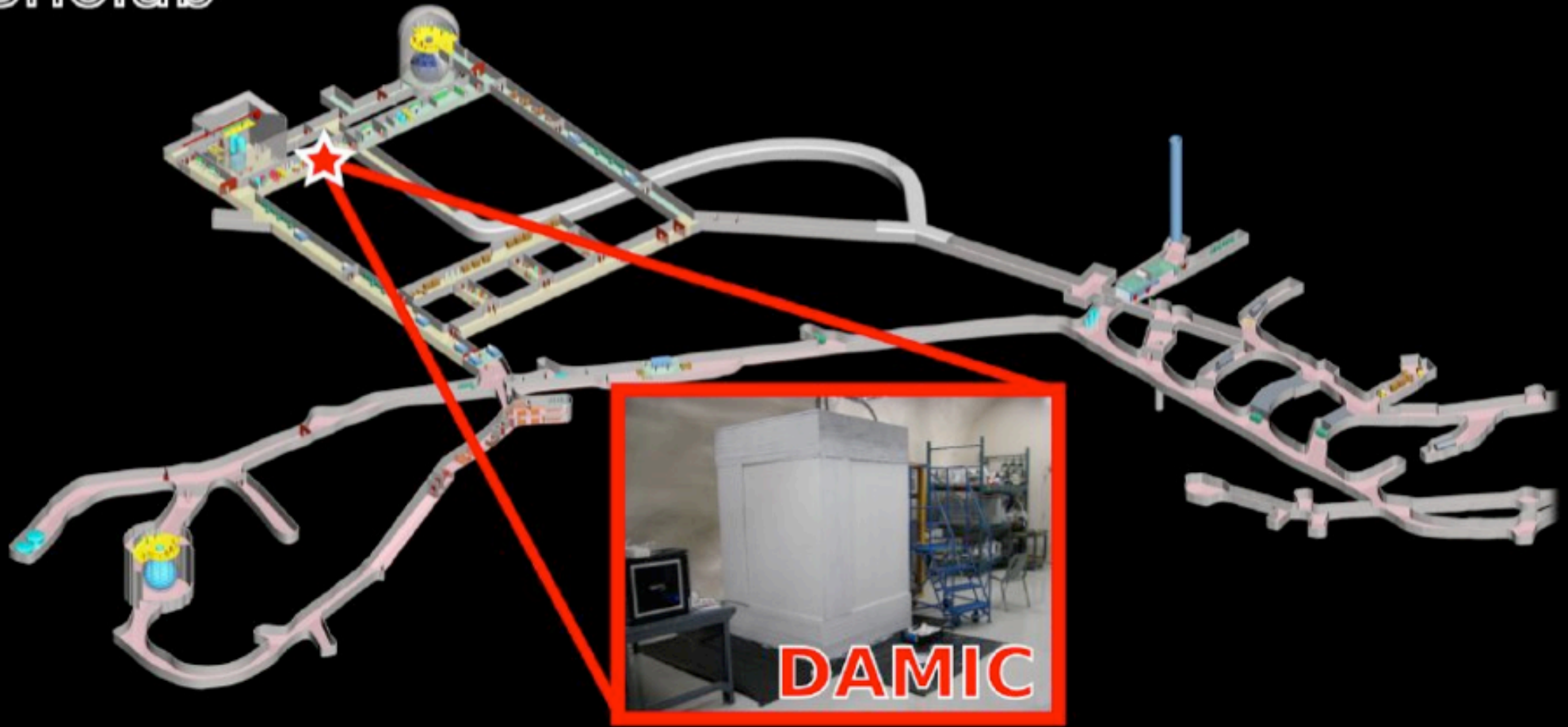

DAMIC R&D program in the J-Drift hall started in early 2013

CAB, FIUNA, Fermilab, LPNHE, SNOLAB, U Chicago, U Michigan, U Zürich, UFRJ, UNAM

DAMIC @ SNOLAB

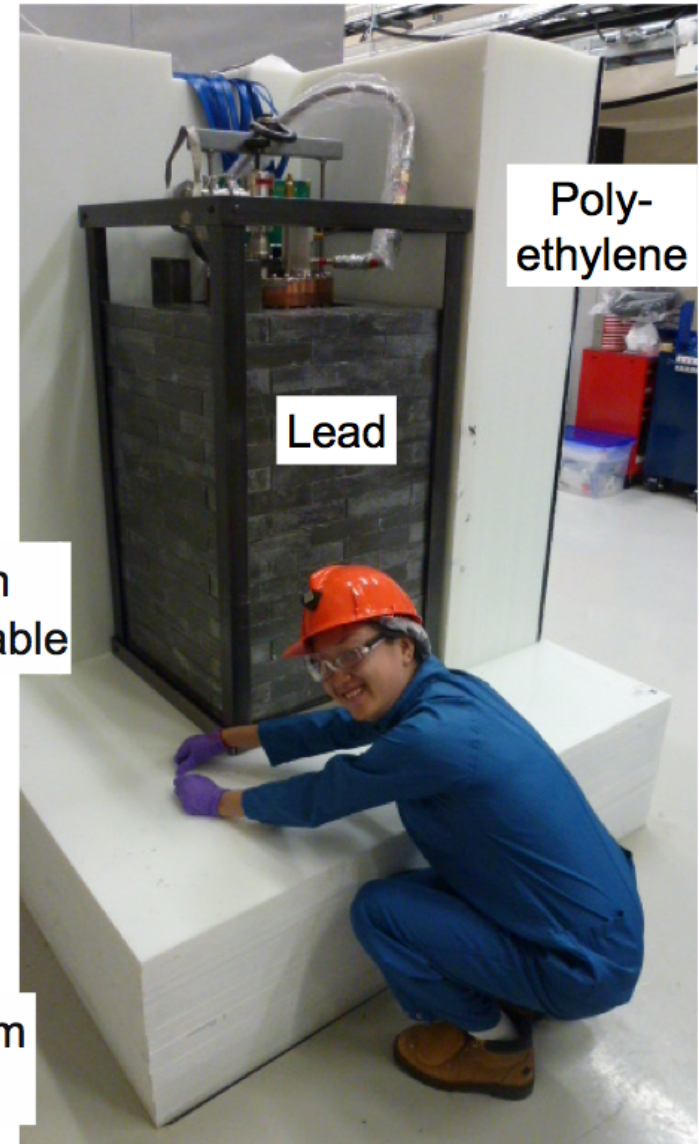
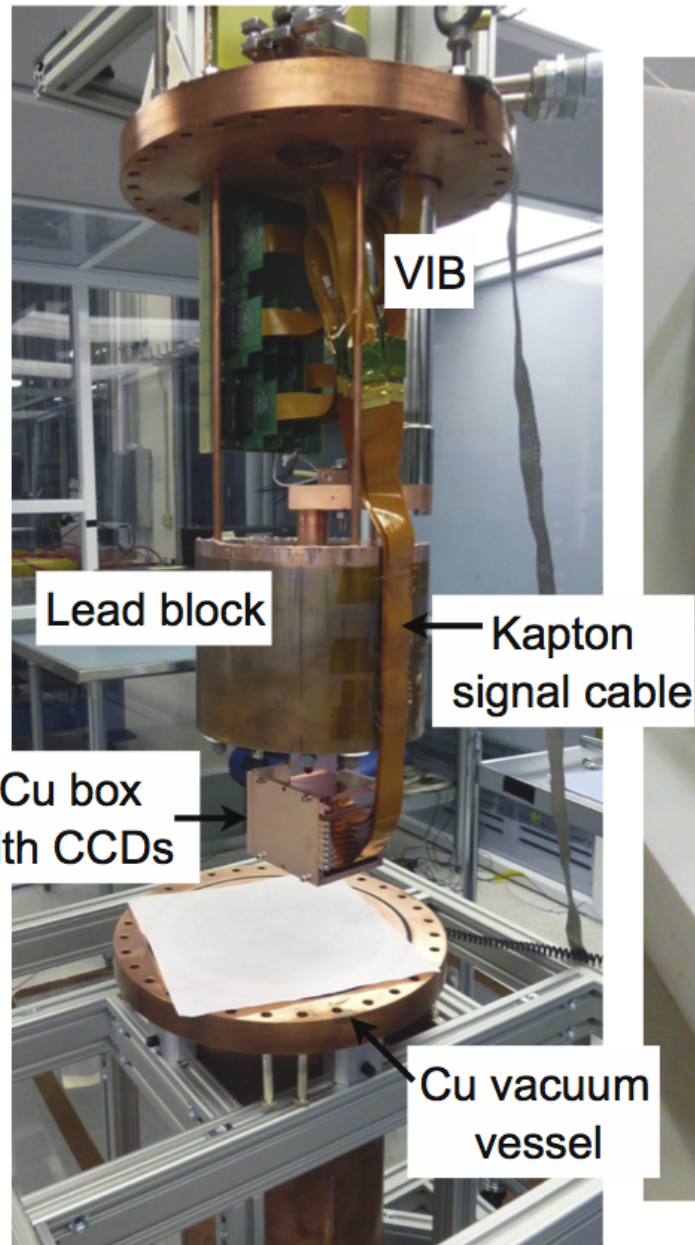
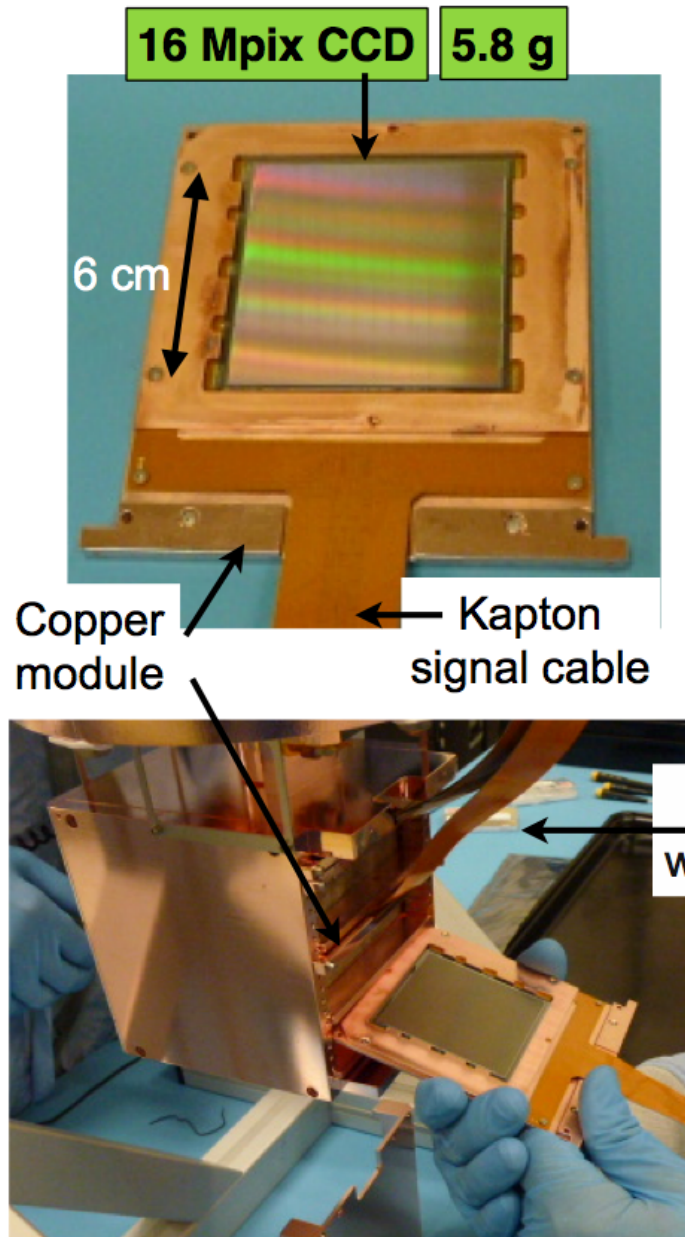

^{55}Fe source spectrum in Chicago chamber

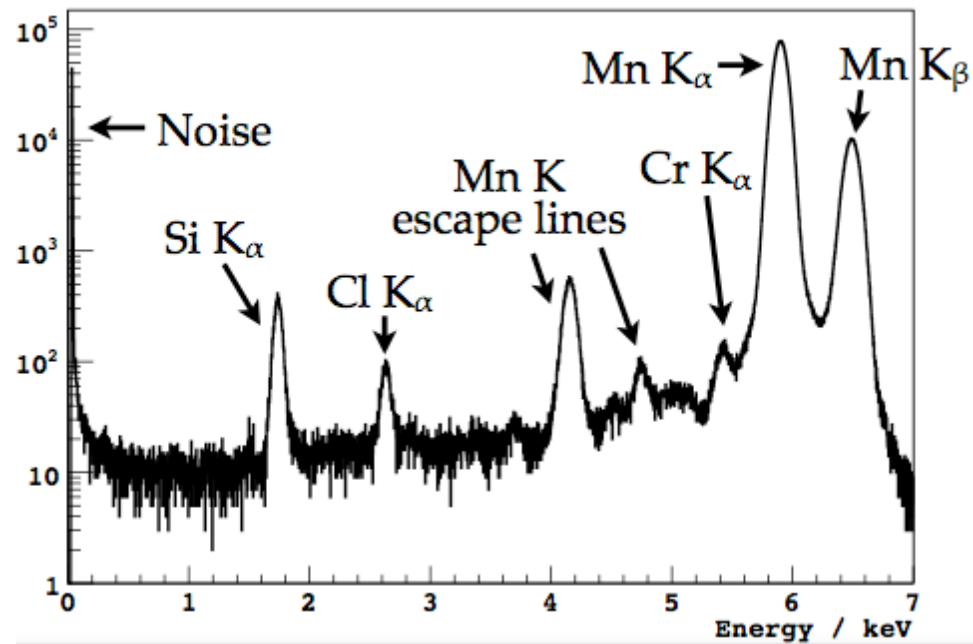

Linearity demonstrated for signals $< 10 e^-$

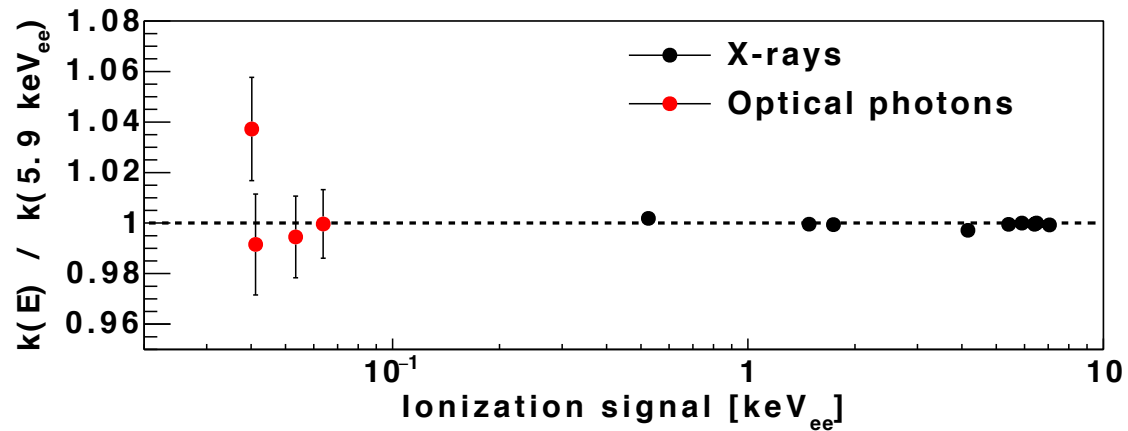

Response to electrons

^3H β spectrum from front

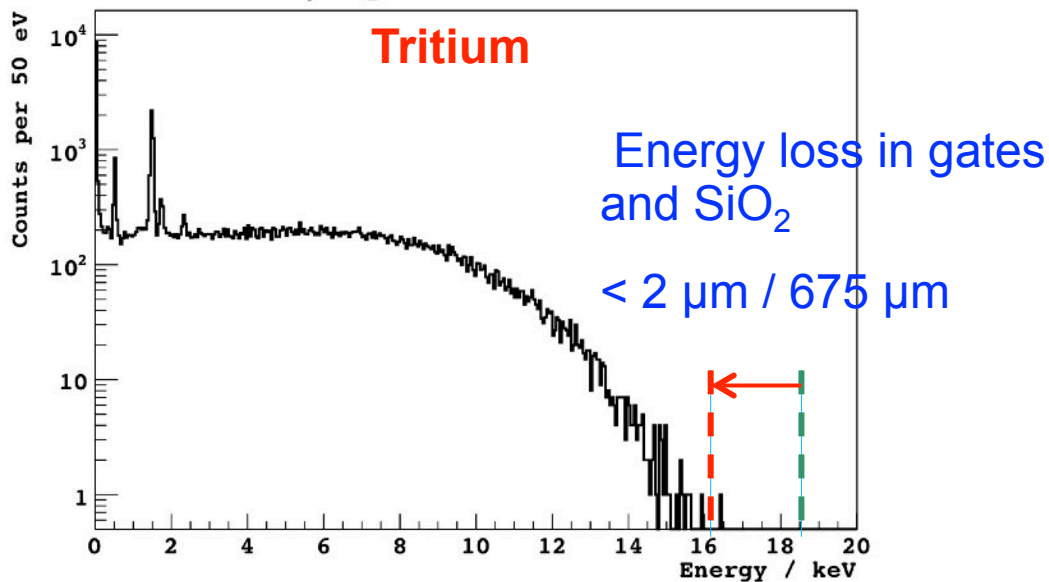

Fluorescence X-rays from ^3H source

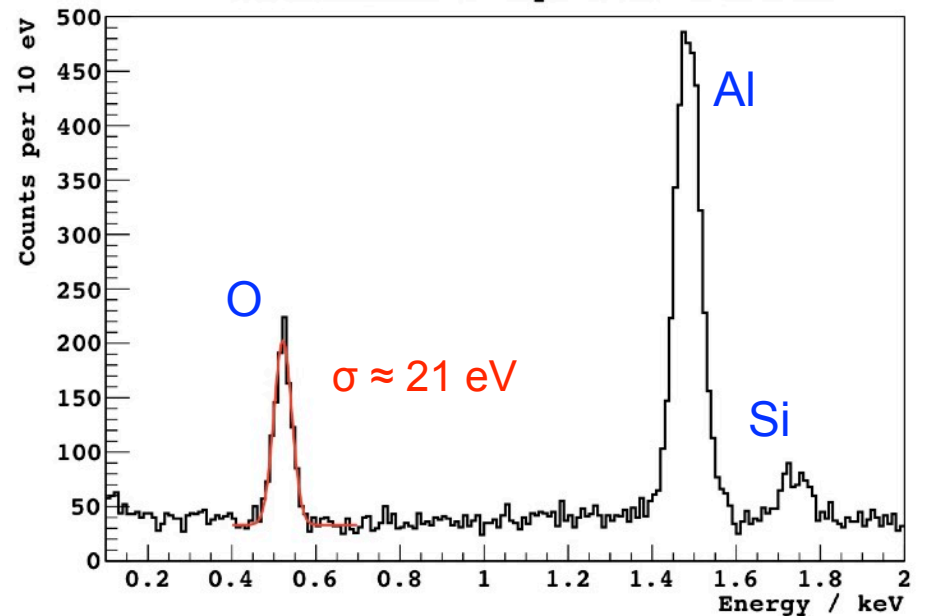

Gamma-rays

Single-scatter
Compton spectrum

^{57}Co source

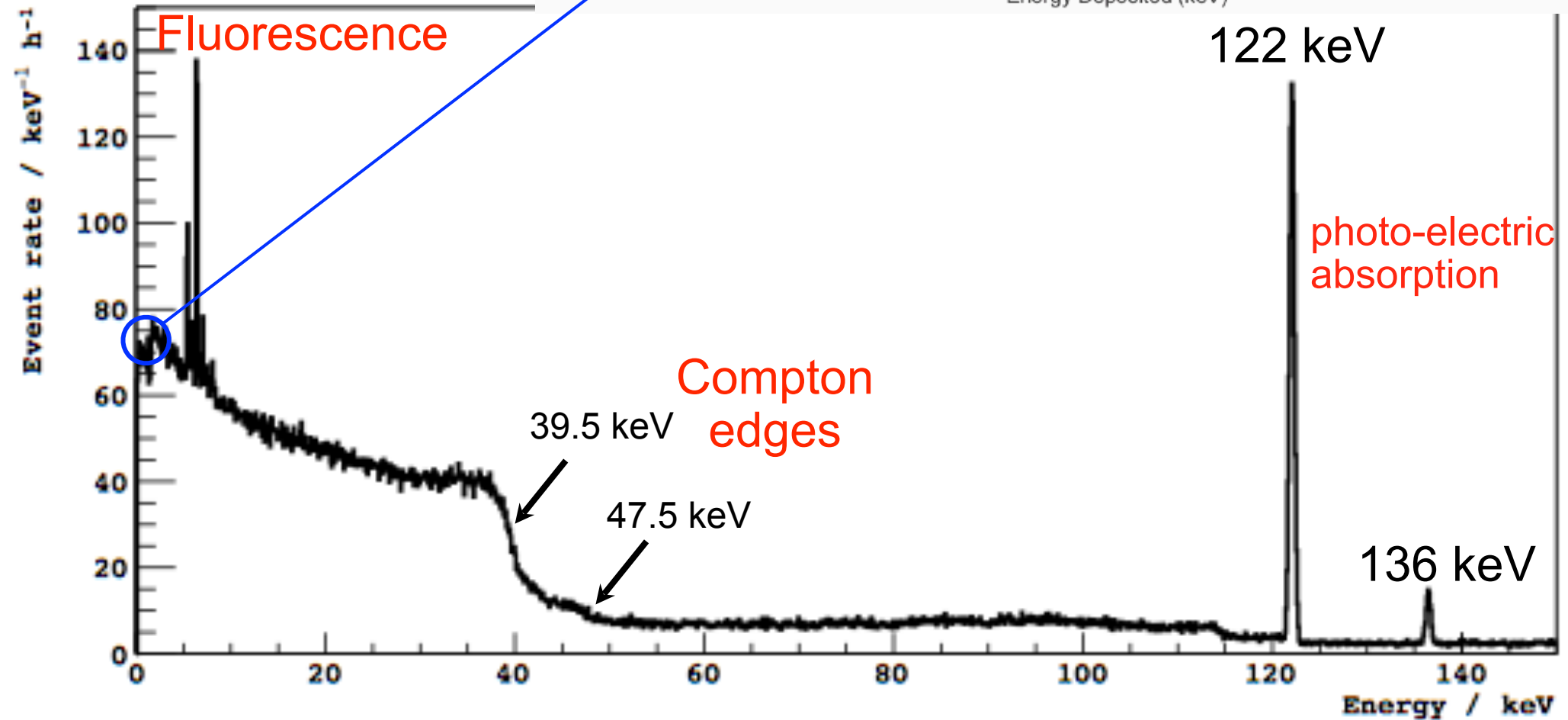
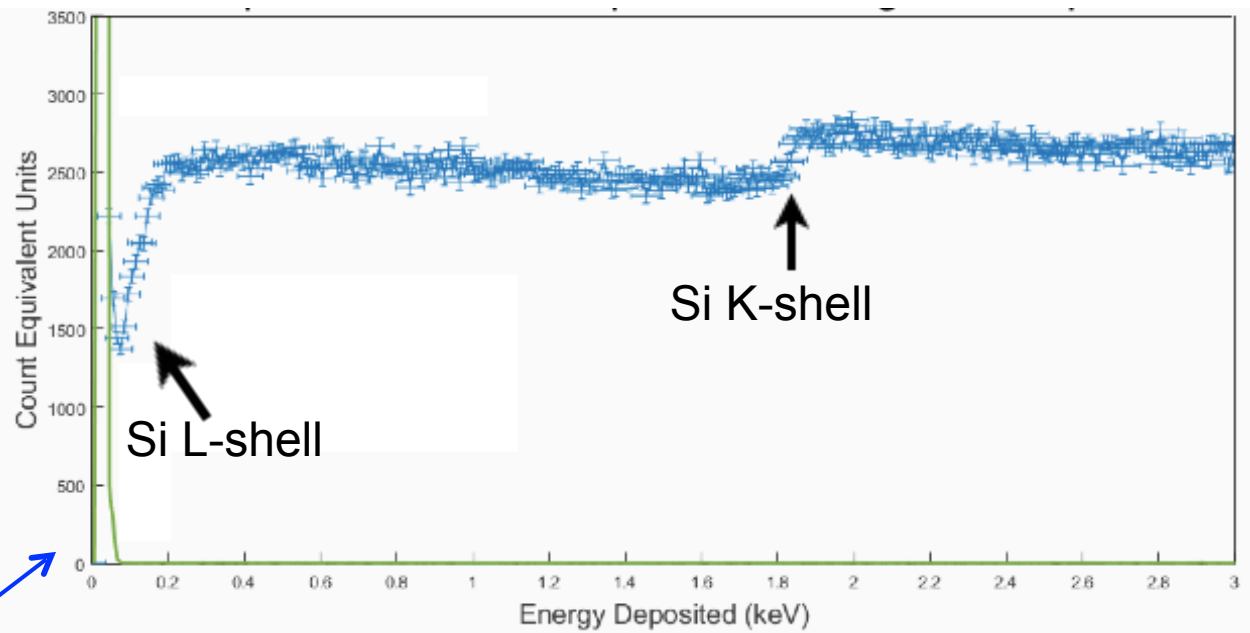

Nuclear recoil calibration

a) Cross-section of setup

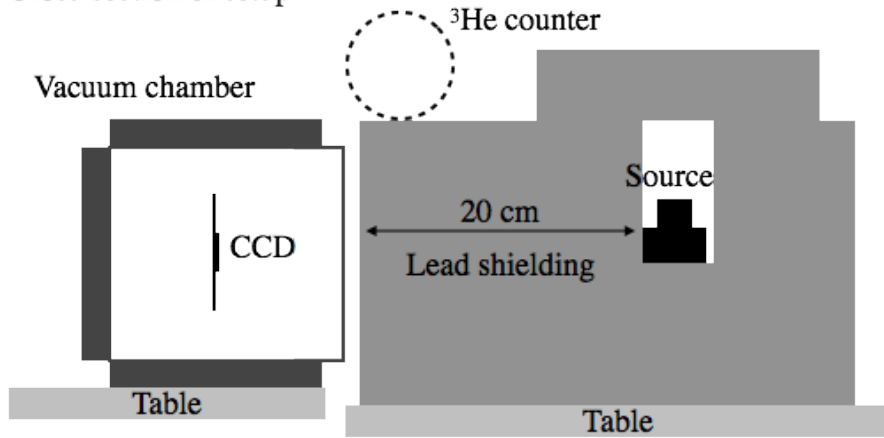

b) ^{124}Sb - ^9Be source detail

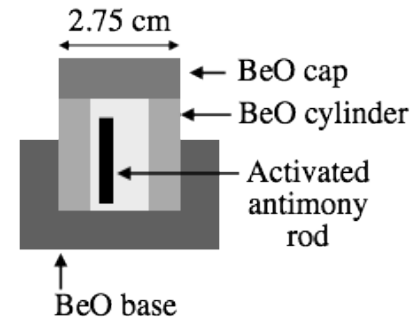

24 keV neutrons
from $^9\text{Be}(\gamma, n)$
reaction

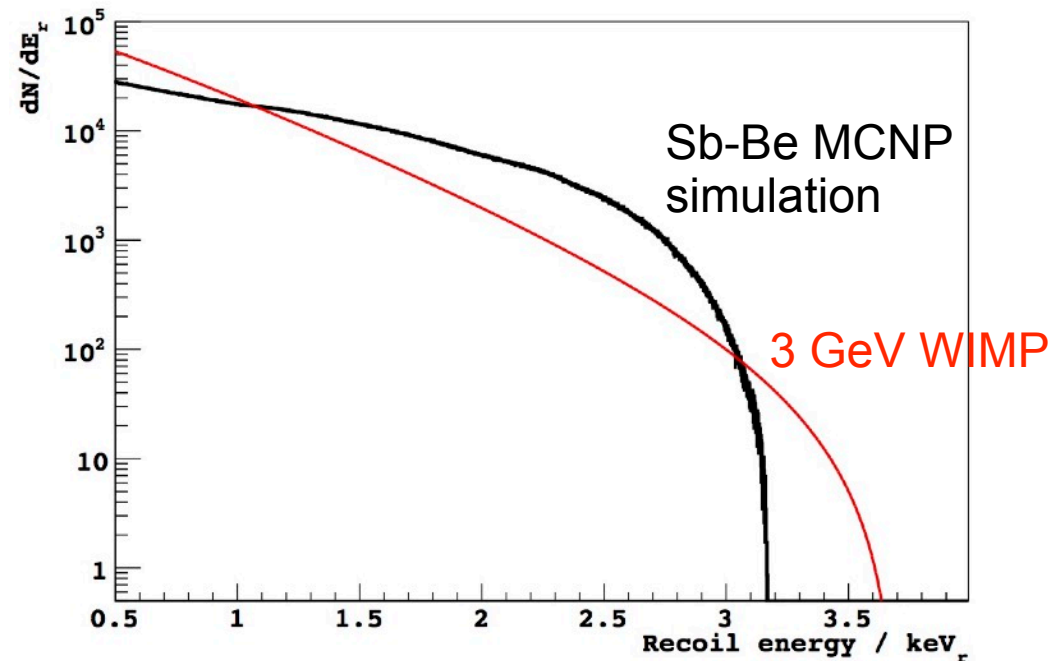
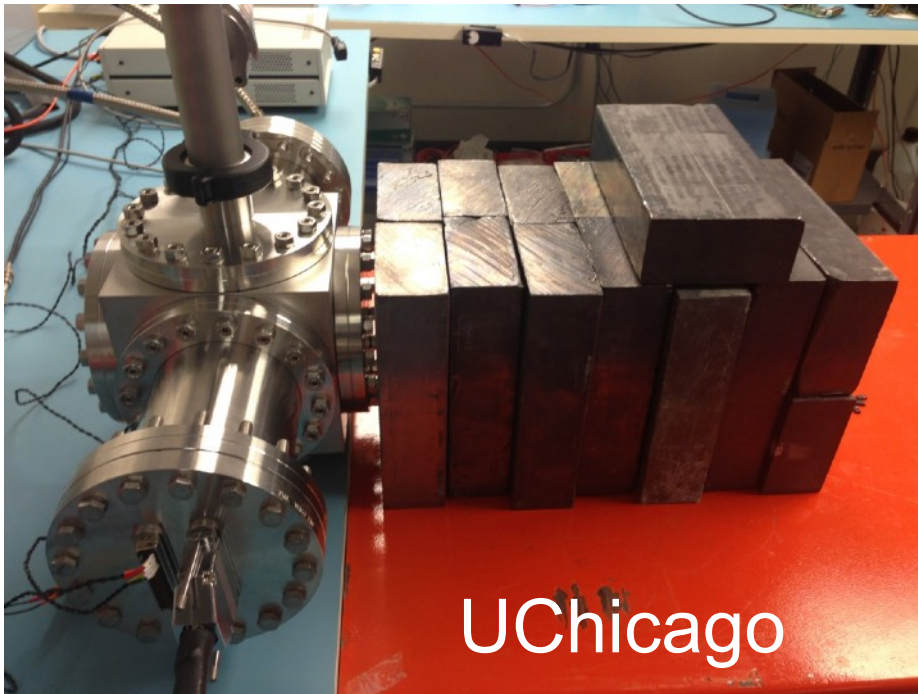

$$E_e \approx 0.2 E_r \text{ (Lindhard)}$$

Nuclear recoil spectrum

- “Neutron-on” with BeO ($n+\gamma$)
“neutron-off” with Al (only γ)
Clear signal from neutron-induced nuclear recoils

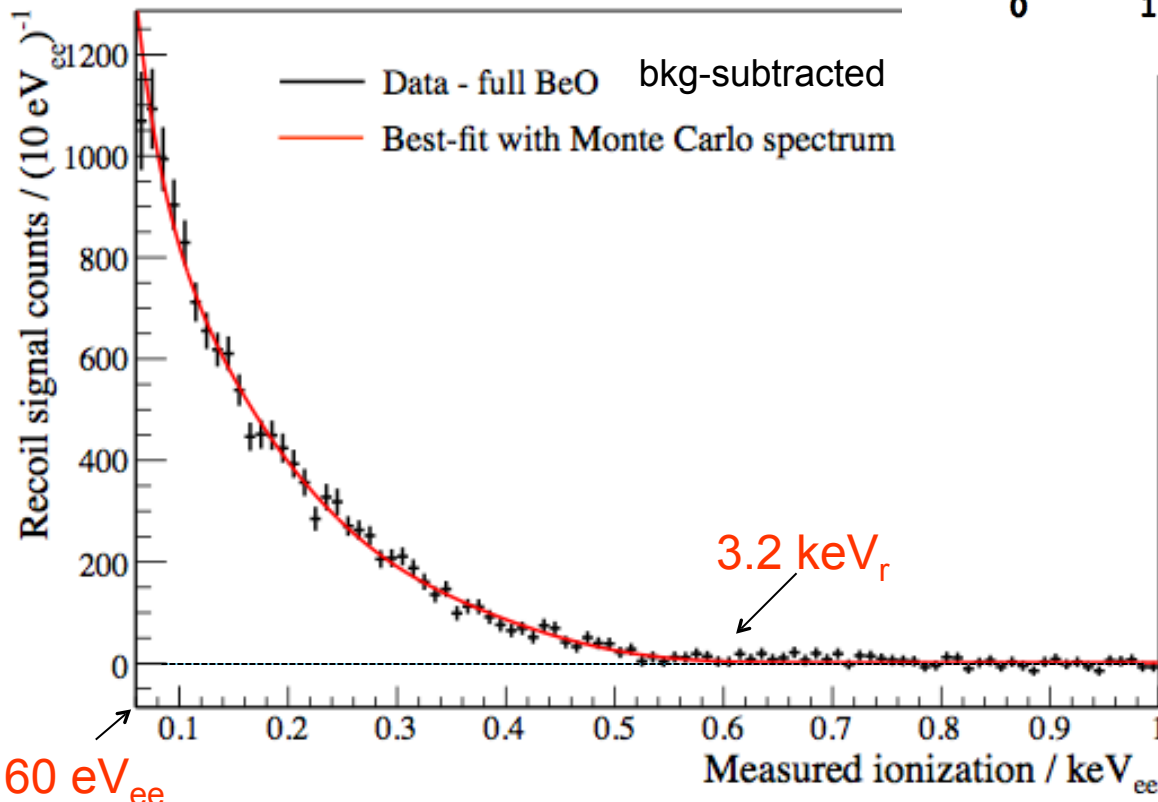
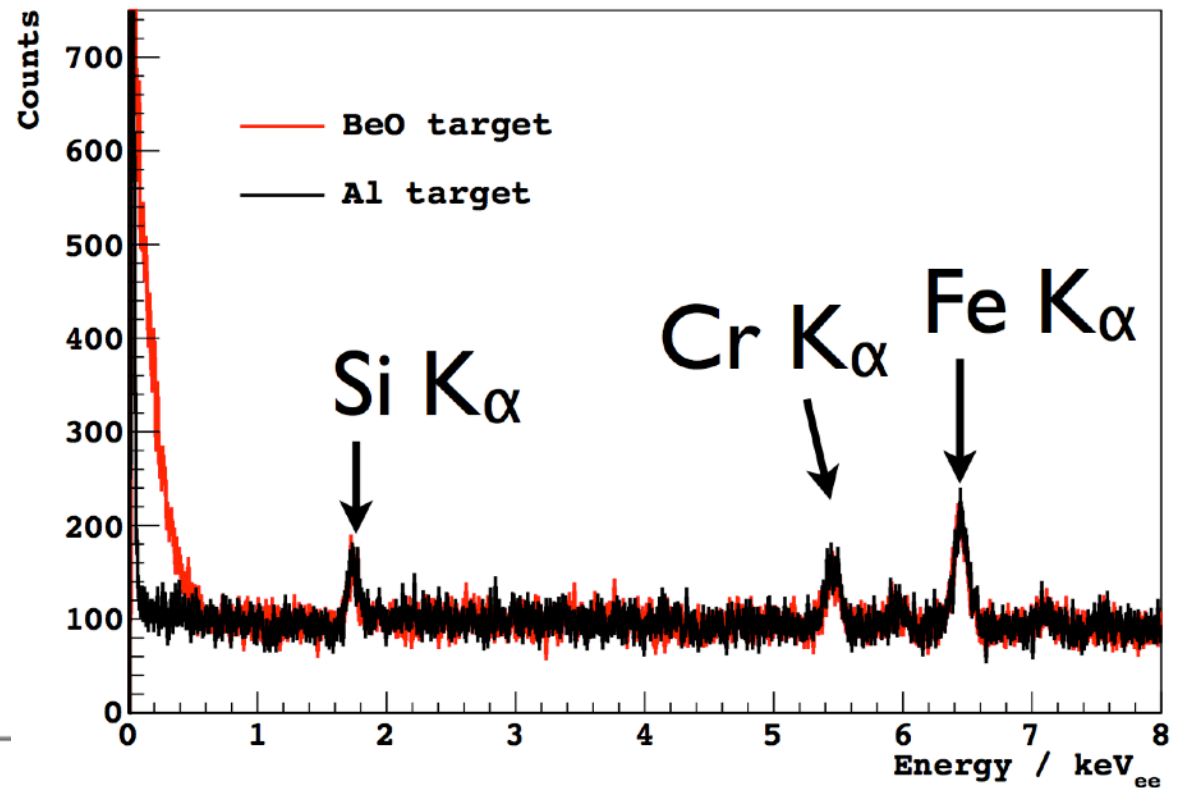

- Nuclear recoil ionization efficiency from adjusting MC E_r to E_e spectrum
- *single* recoil spectrum
- systematic uncertainties are small, dominated by 9% uncertainty on total predicted rate

Nuclear-recoil ionization efficiency in silicon

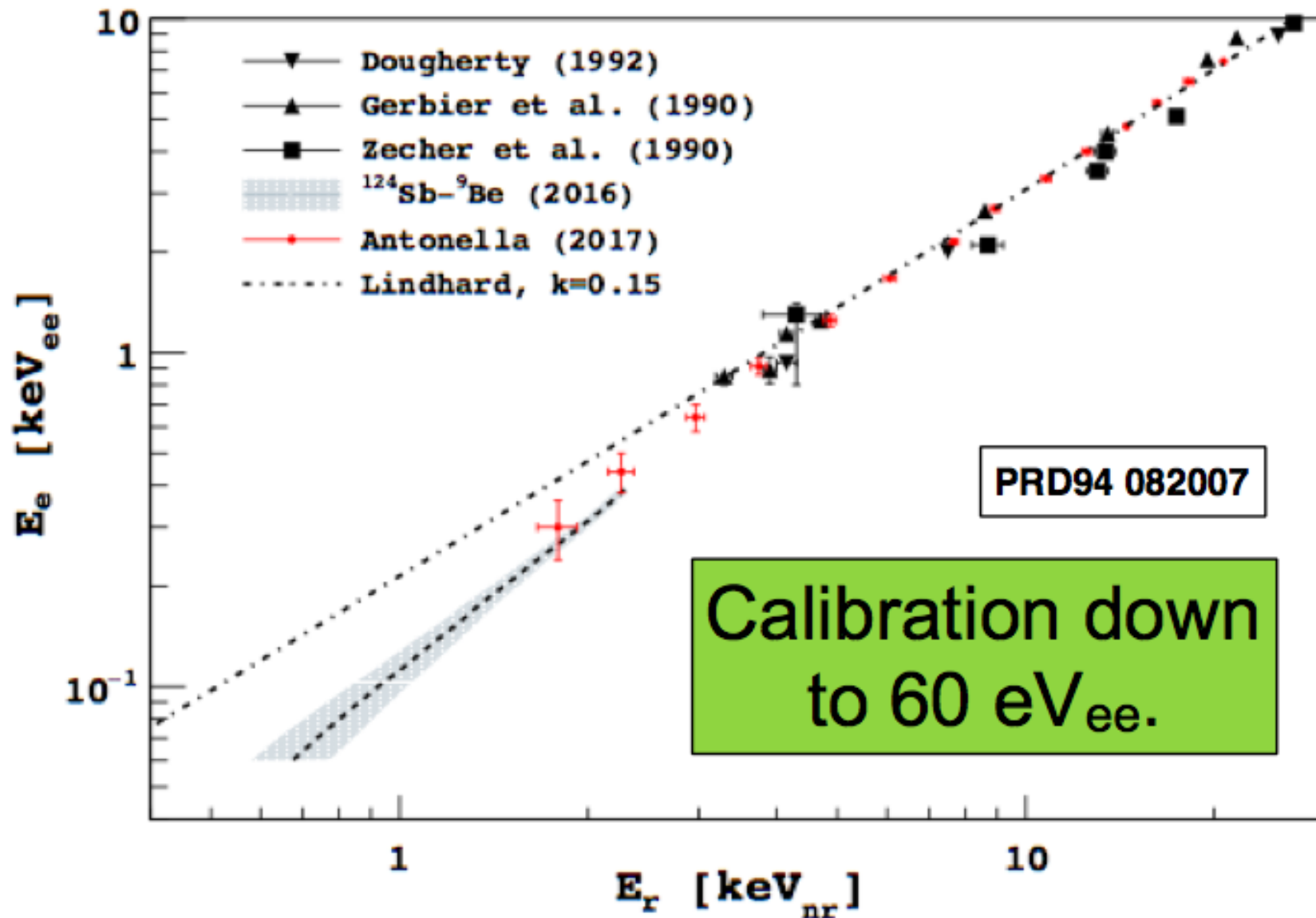

deviation from Lindhard theory observed – crucial for low-mass WIMP searches with silicon detectors

Background, background, background

- **Lead shielding** to stop environmental γ rays

Inner 2" shielding made of ancient lead to avoid bremsstrahlung γ s from ^{210}Pb β -decay (22 yrs half-life)

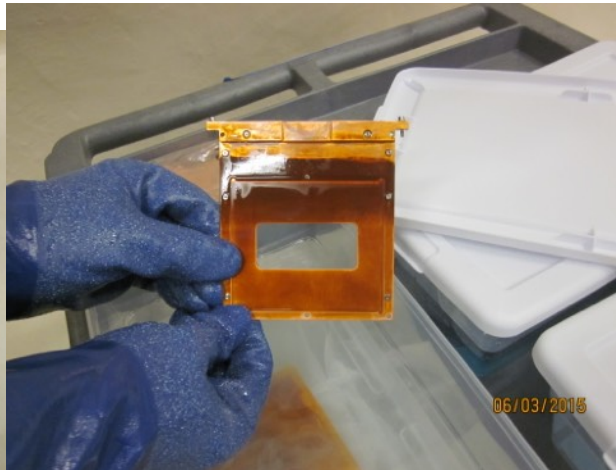
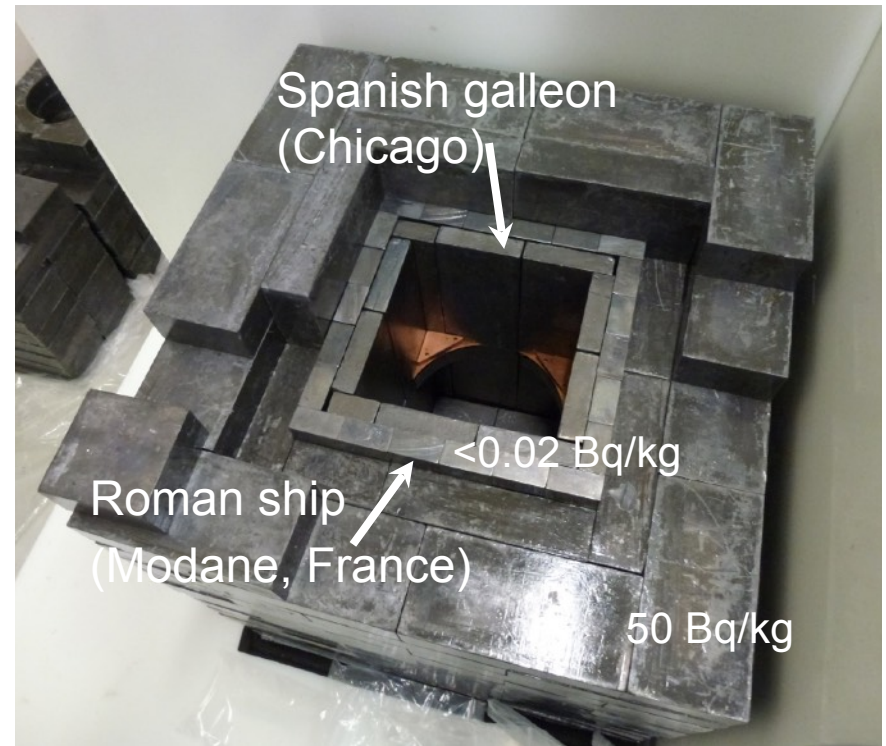

- **Material selection and cleaning:** copper machining, "secret" recipe etching (surface bkg)

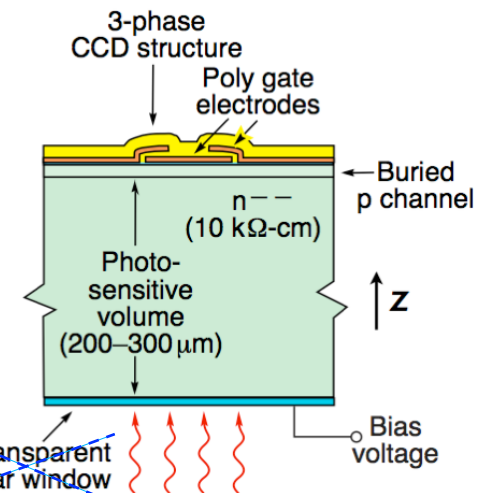

Background tour-de-force

- Since 2013 background reduced by $>10^3$
- ≈ 5 dru achieved before DAMIC100 installation (similar to competitors)

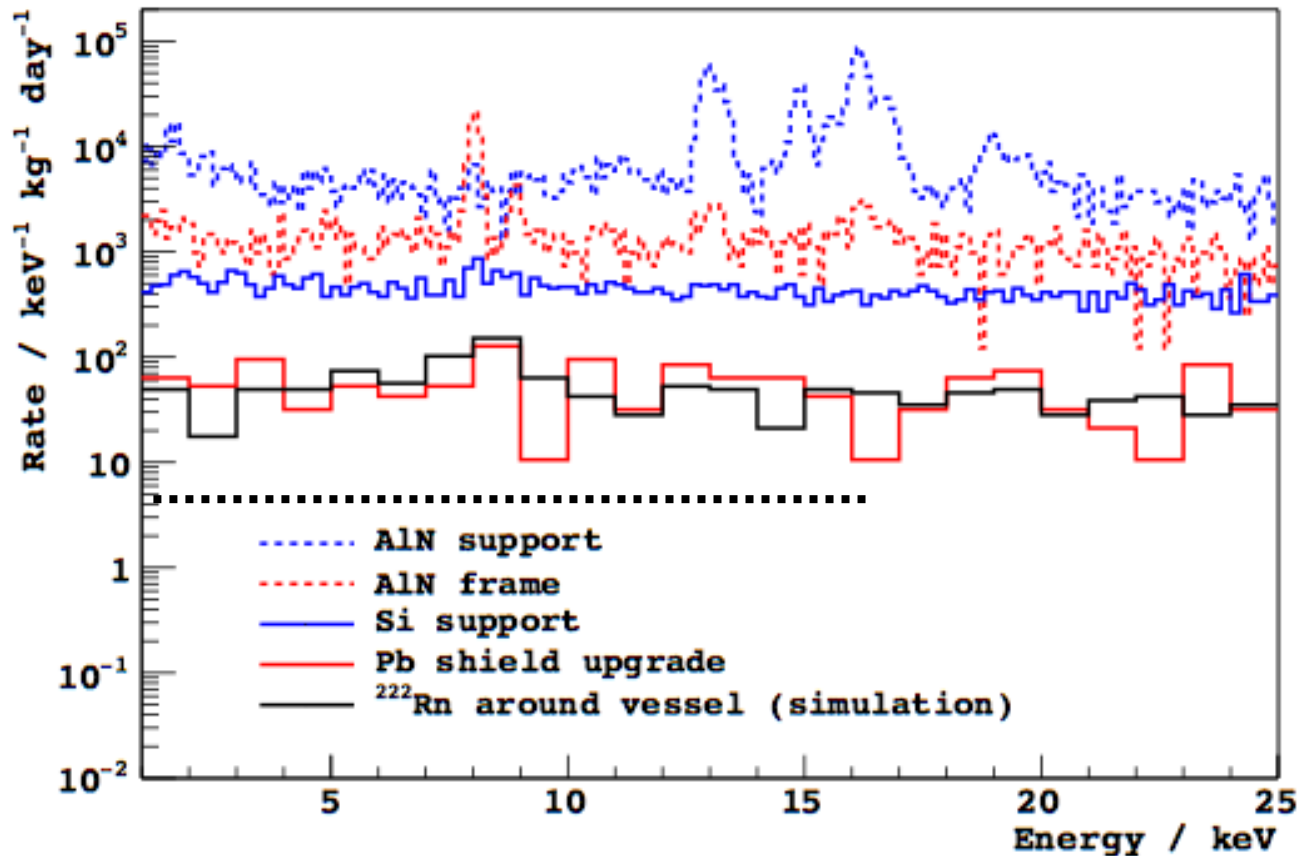

In the last year:

- Seven interventions at SNOLAB.
- Nitrogen purge installation (Radon).
- Improvements in treatment of copper surfaces.
- Suppression of background from thermal neutron captures in copper.
- Mitigation of background from condensation e.g. ³H.

- Background rate may be smaller in DAMIC100: new CCD box and packages, roman lead

DAMIC background characterization

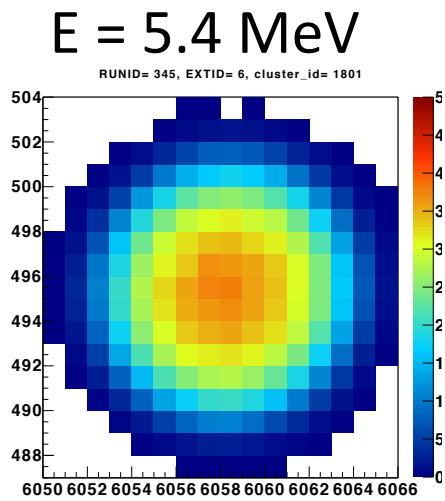

1 $\Delta t = 17.8$ d

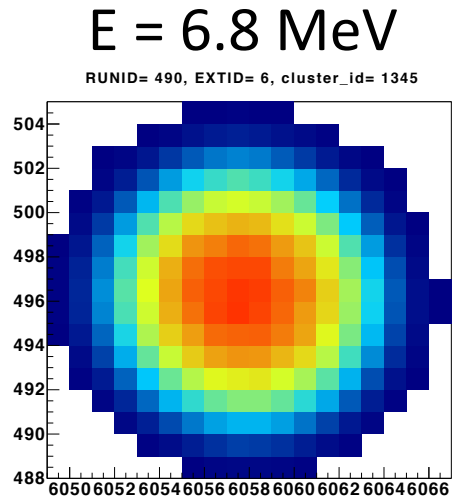

2 $\Delta t = 5.5$ h

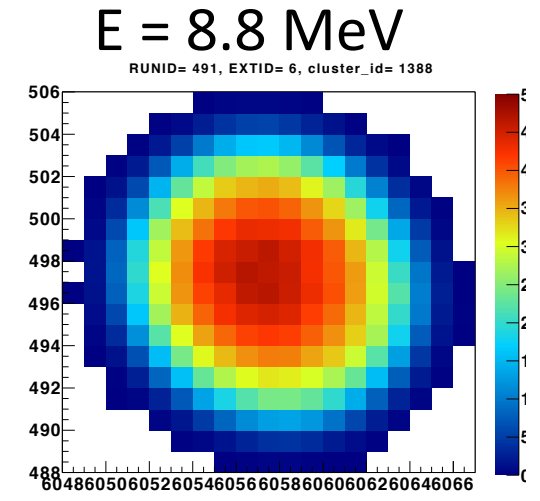

3

Three α at the same location!

Powerful method to measure U/Th bkg in the bulk – ppt limits 2015 JINST 10 P08014

Example of $\alpha + \beta$

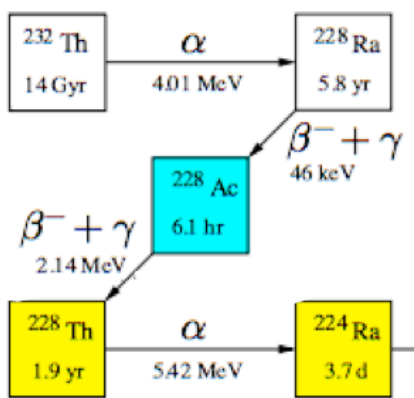

1

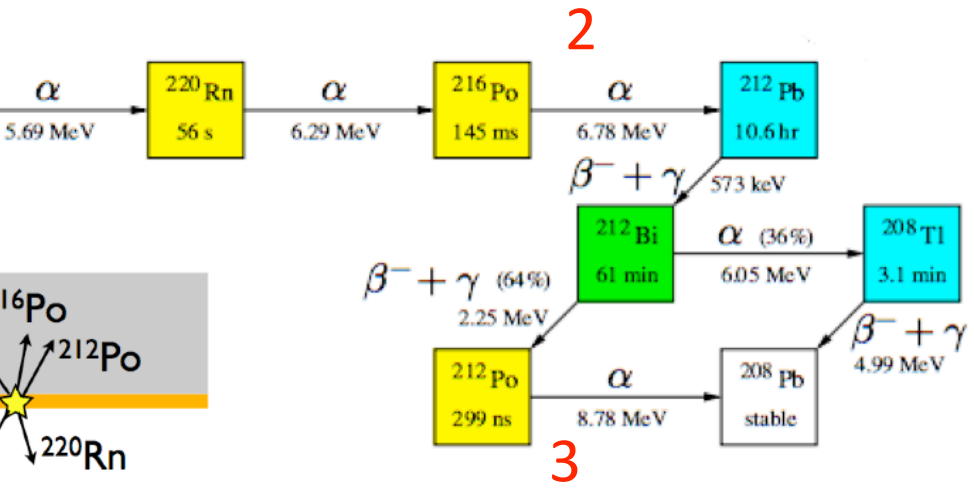
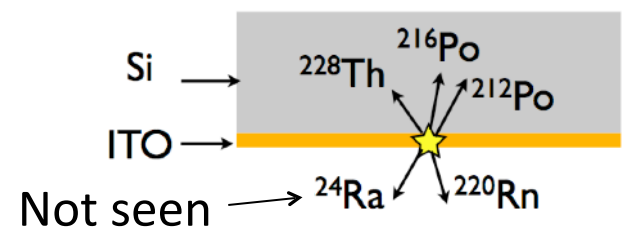

2

3

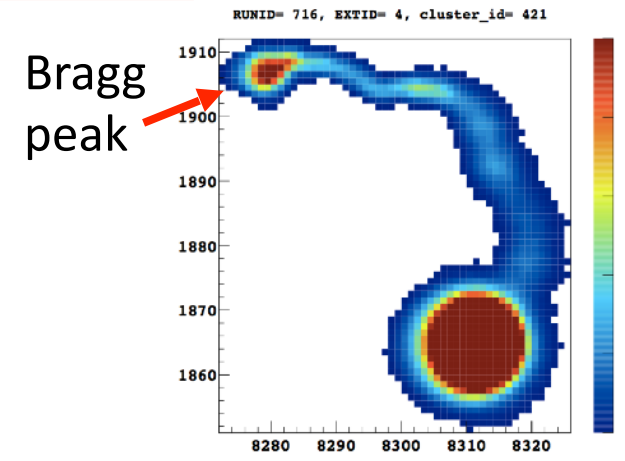

Bragg peak

Dark Matter search with R&D data

- R&D focused on background reduction and CCD operation.
- We also took a small amount of data to be used for a first limit. Background ≈ 30 dru (now 5 dru!). Exposure ≈ 0.6 kg day. Goal: develop search tools and demonstrate CCD science potential
- Part of exposure (0.23 kg day) taken with *hardware binning*

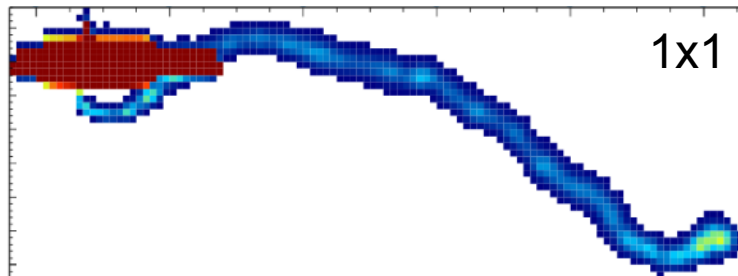

α - β events

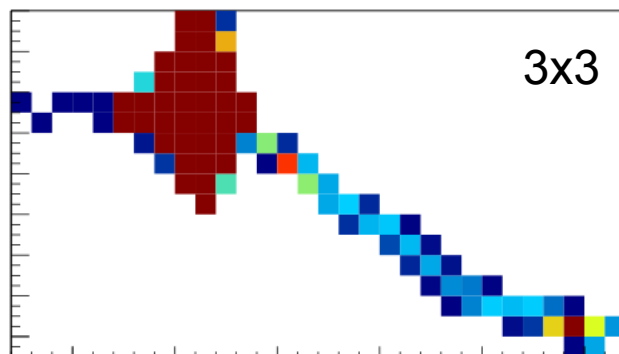

charge of several pixels can be added together before moving it to the readout node

some loss of spatial resolution but improved signal to noise (same readout noise but more charge in a binned pixel)

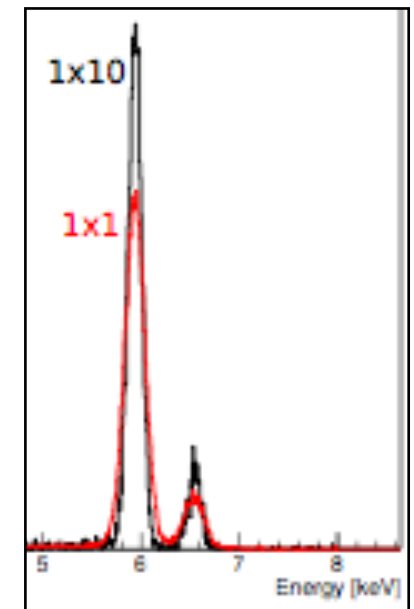

^{55}Fe source:
improved energy resolution

Dark Matter search with R&D data

Measure E and σ_{xy} for every cluster event.

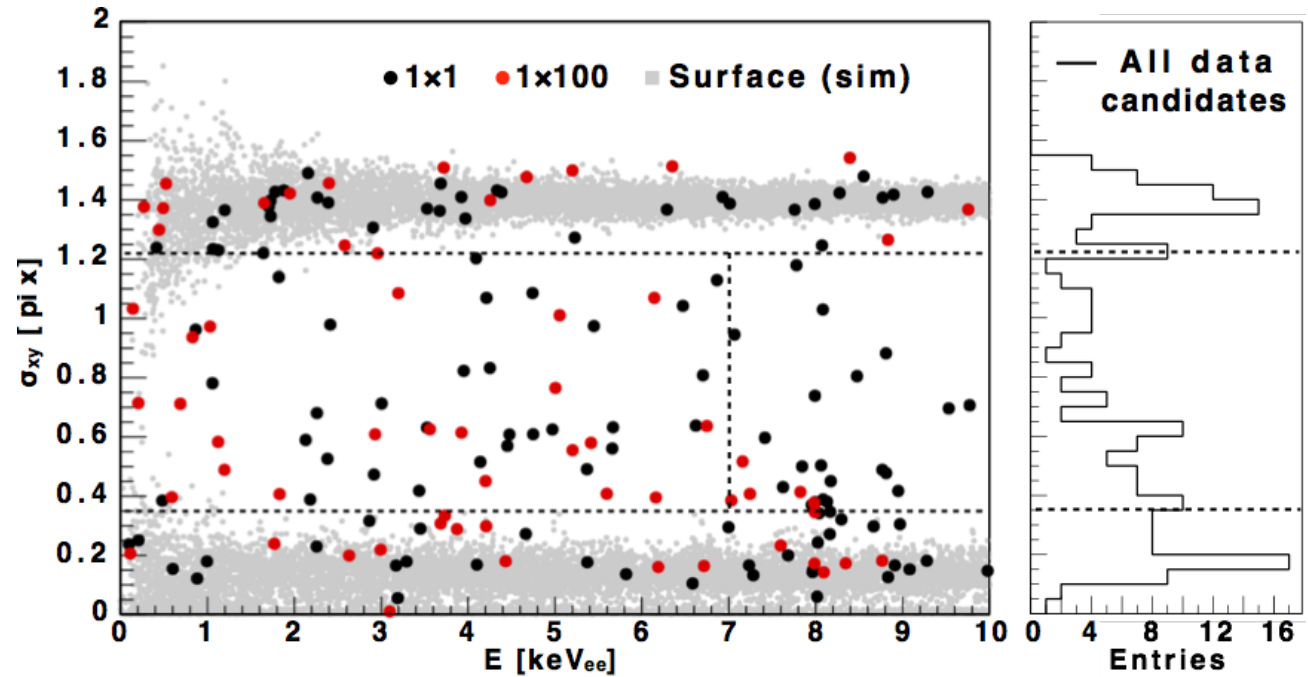
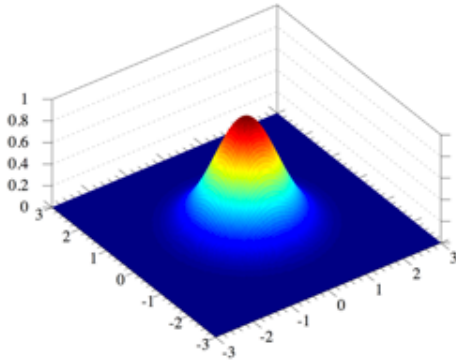

Observed spectrum in fiducial region

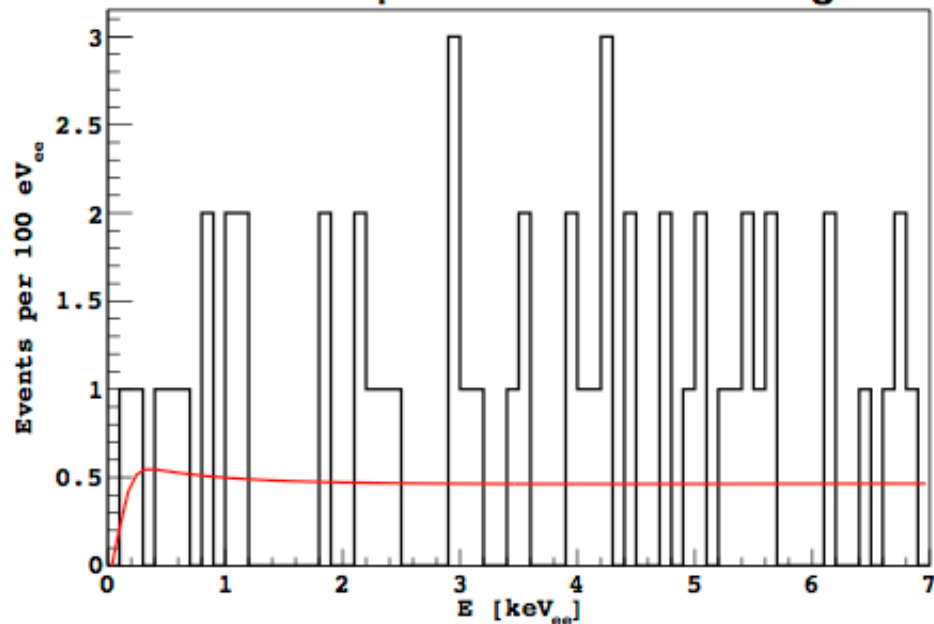

Spectrum consistent with Compton scattered electrons in fiducial region:

No WIMP signal

Exclusion limit

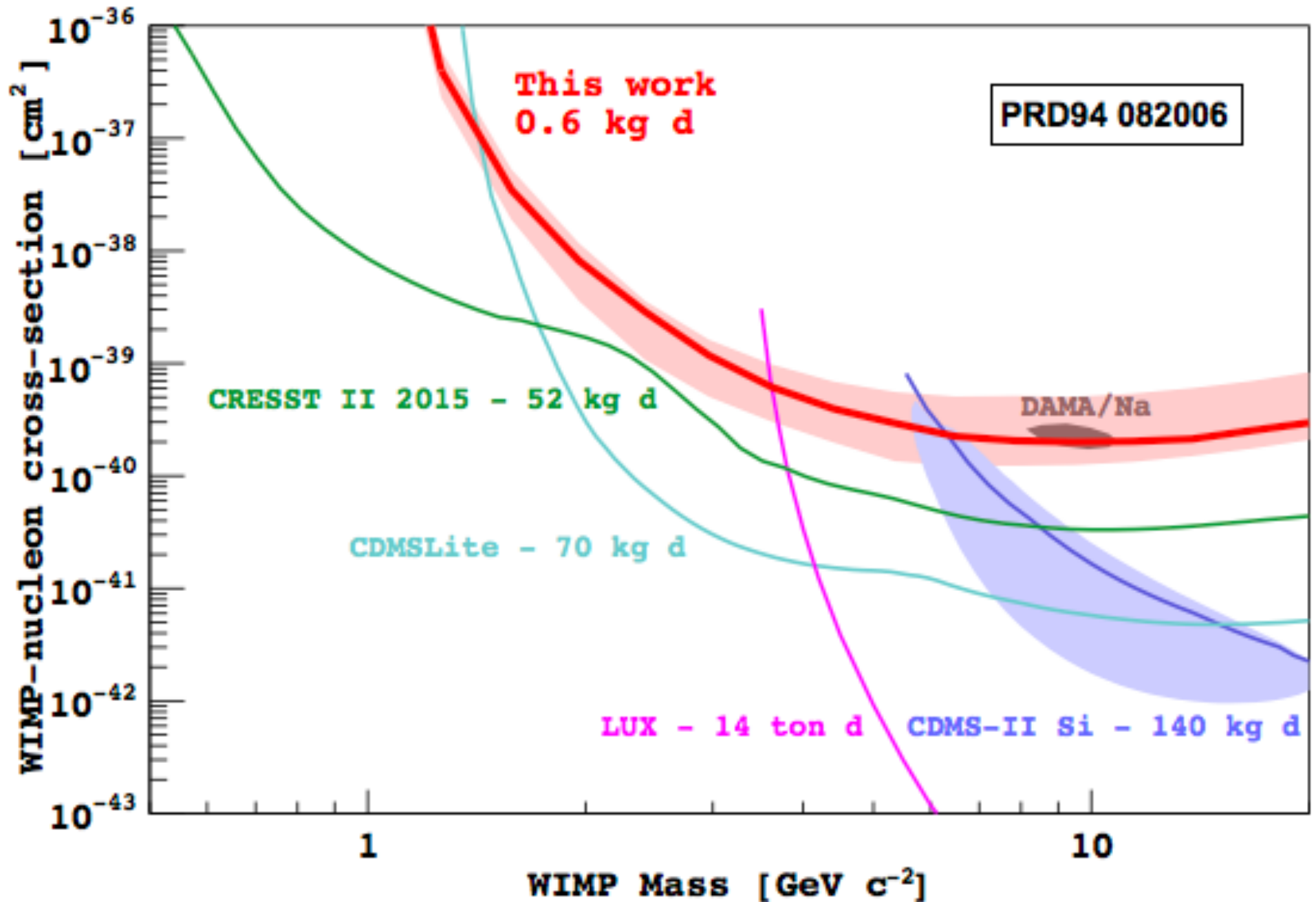

Hidden photon DM search

readout noise +
leakage current +
Hidden Photon

NOTE: 1x100
binning

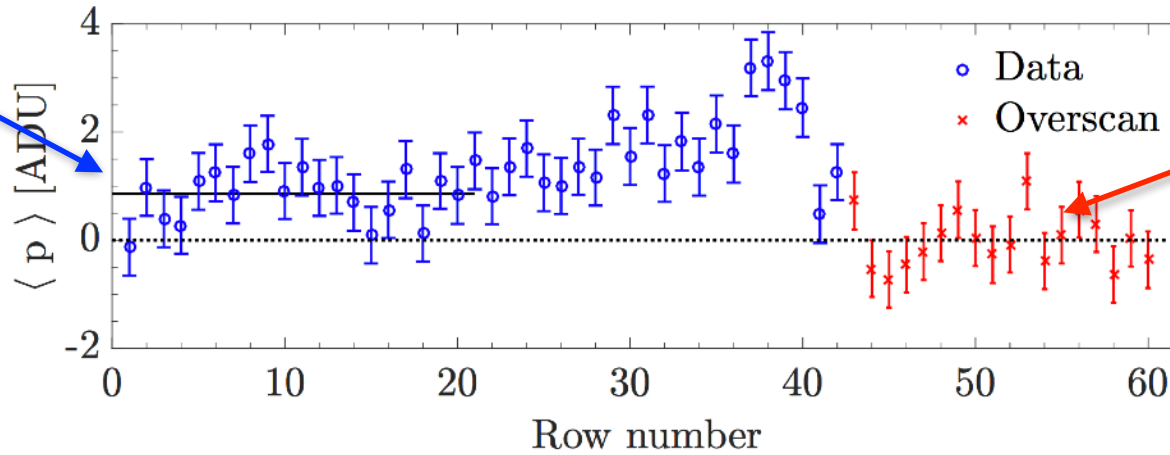

only readout
noise in the
overscan rows

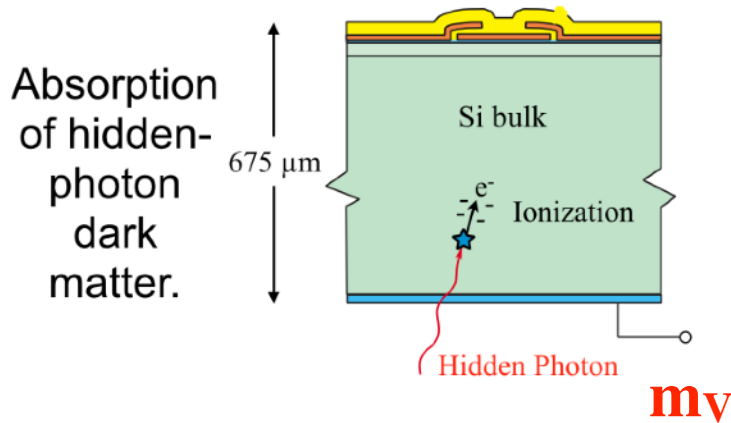

hidden photon absorption would produce $m_V / 3.6 \text{ eV}$ charge carriers in silicon:
HP sensitivity in the charge distribution

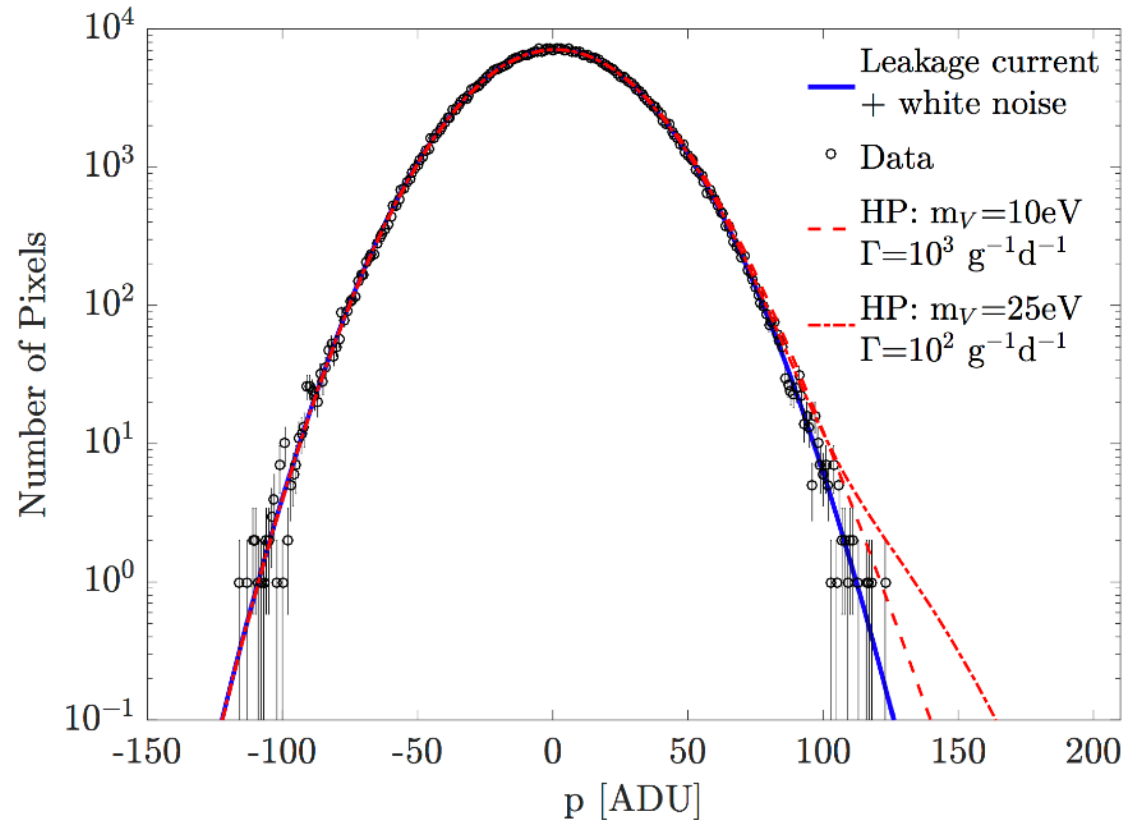

Hidden photon limit

1 week of data of 1 CCD

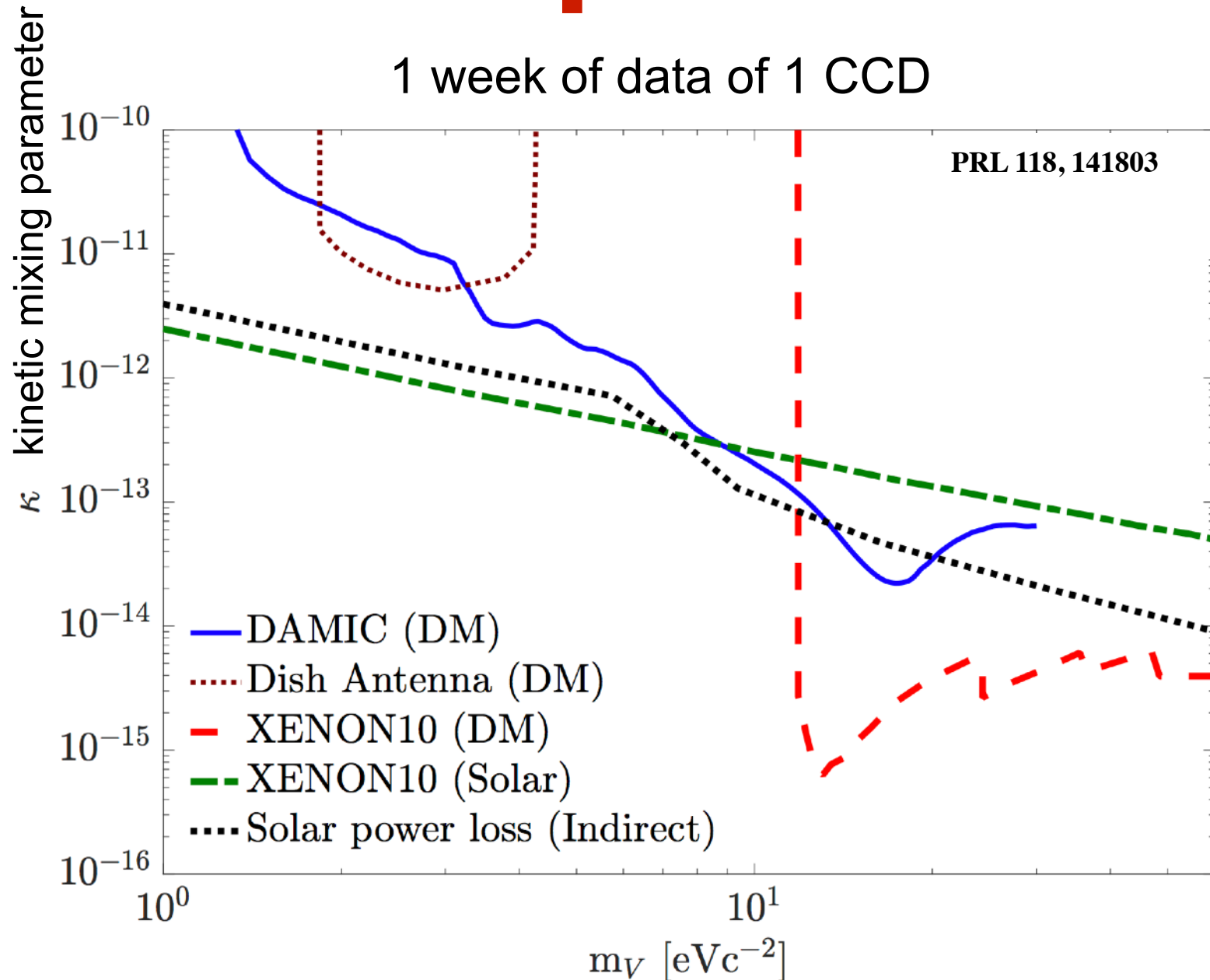

Lowest leakage current ever achieved in a Si detector

10^{-21} A/cm² !

DAMIC now

- Already achieved radioactive background (**5 dru**) and a low threshold (**$\approx 10 e^-$**) performance.
- Stack of 16 Mpixel CCDs: DAMIC100 in current SNOLAB vacuum vessel and shielding.
- Installation took place in January, results with ≈ 10 kg day of data expected in 2017.
- Ongoing R&D for thicker, larger-area CCDs for a lower-noise, lower-background kg-size detector.

DAMIC-1K

- A kg-size experiment with **0.1 dru** background and $\leq 2e^-$ threshold
- To lead the exploration of WIMPs and dark sector candidates in the low-mass DM parameter space

DAMIC-1K and WIMPs

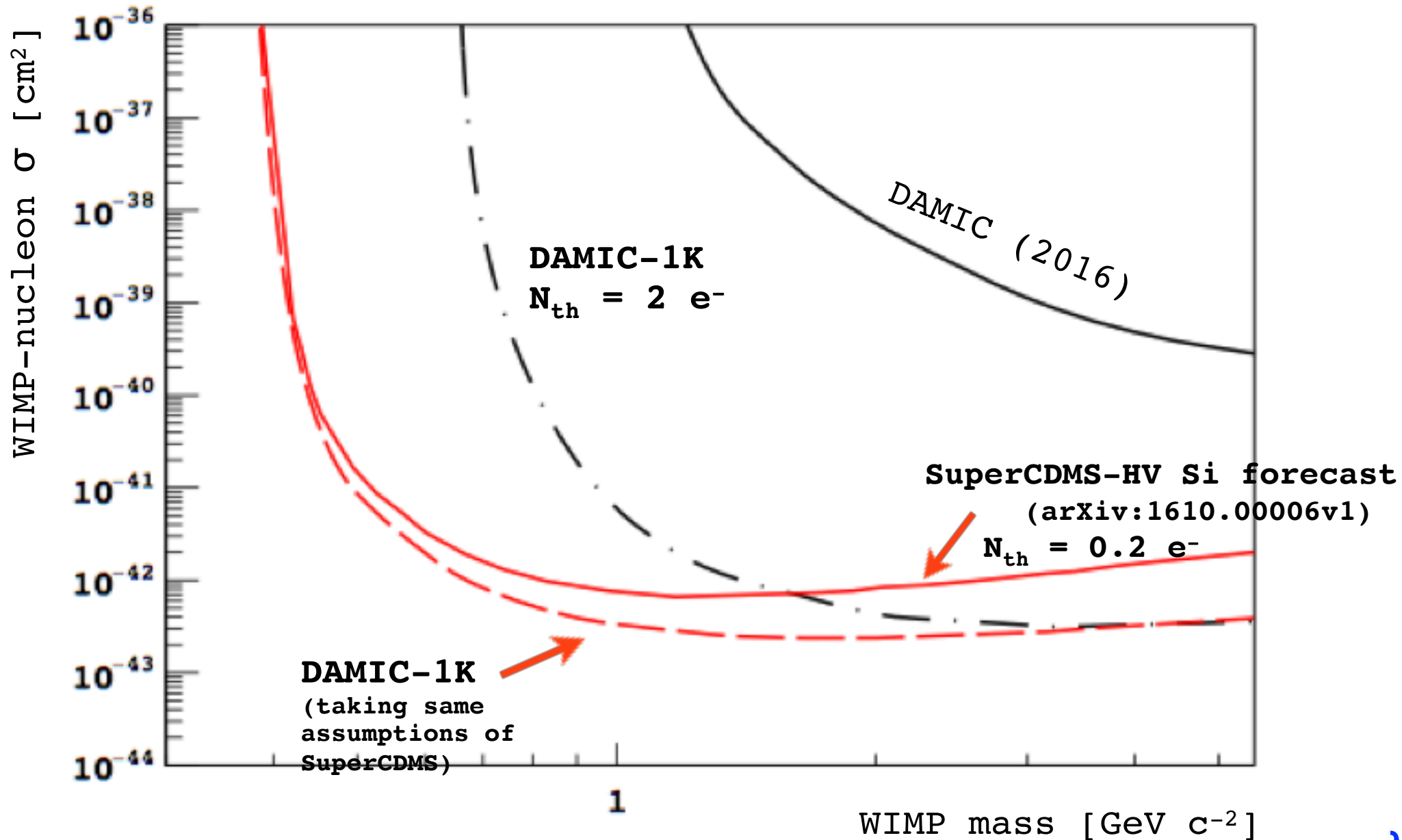

DAMIC-1K not limited by ^{32}Si bkg.

DAMIC-1K and dark sector

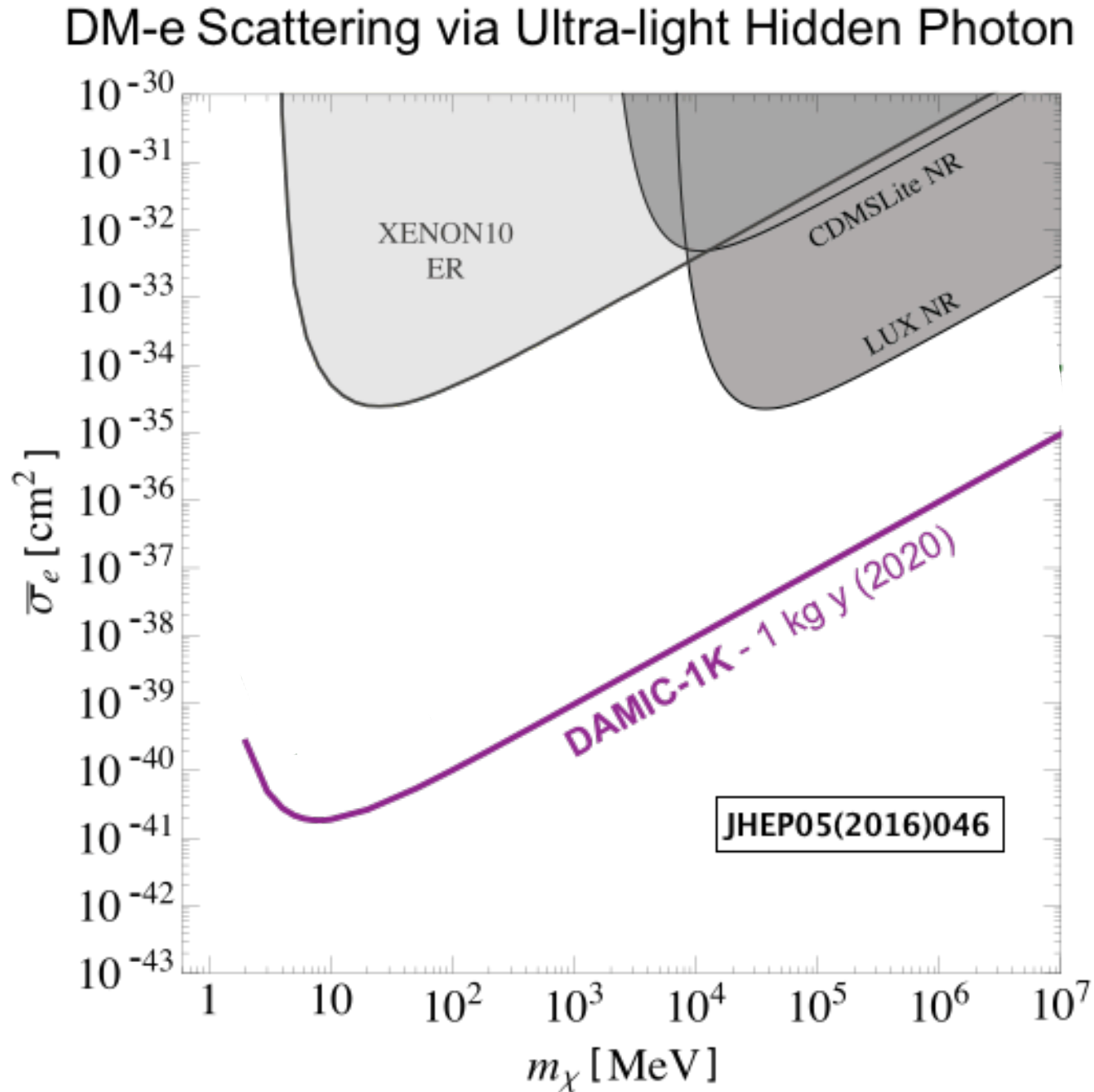

DAMIC-1K and dark sector

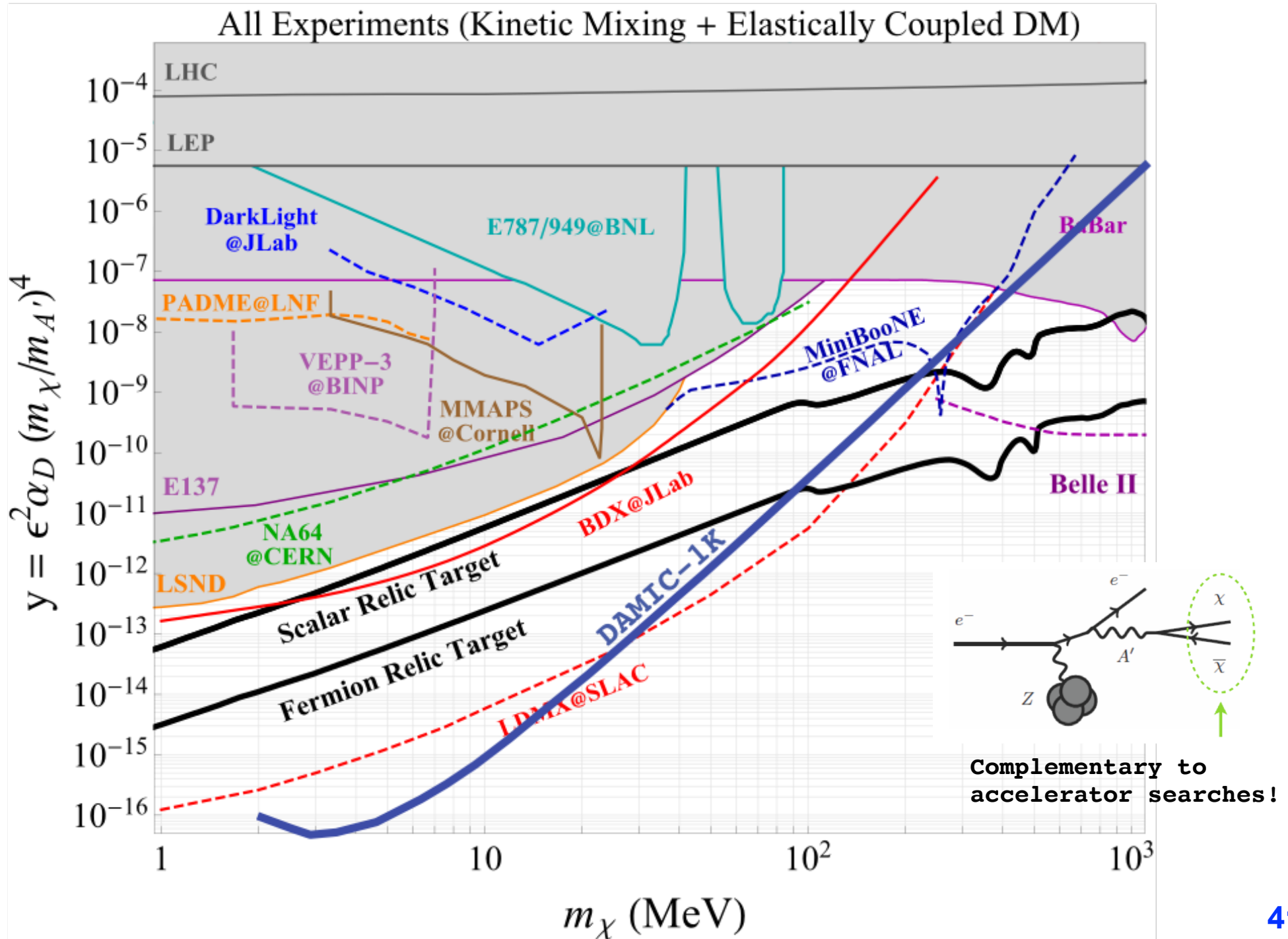

DAMIC-1K and dark sector

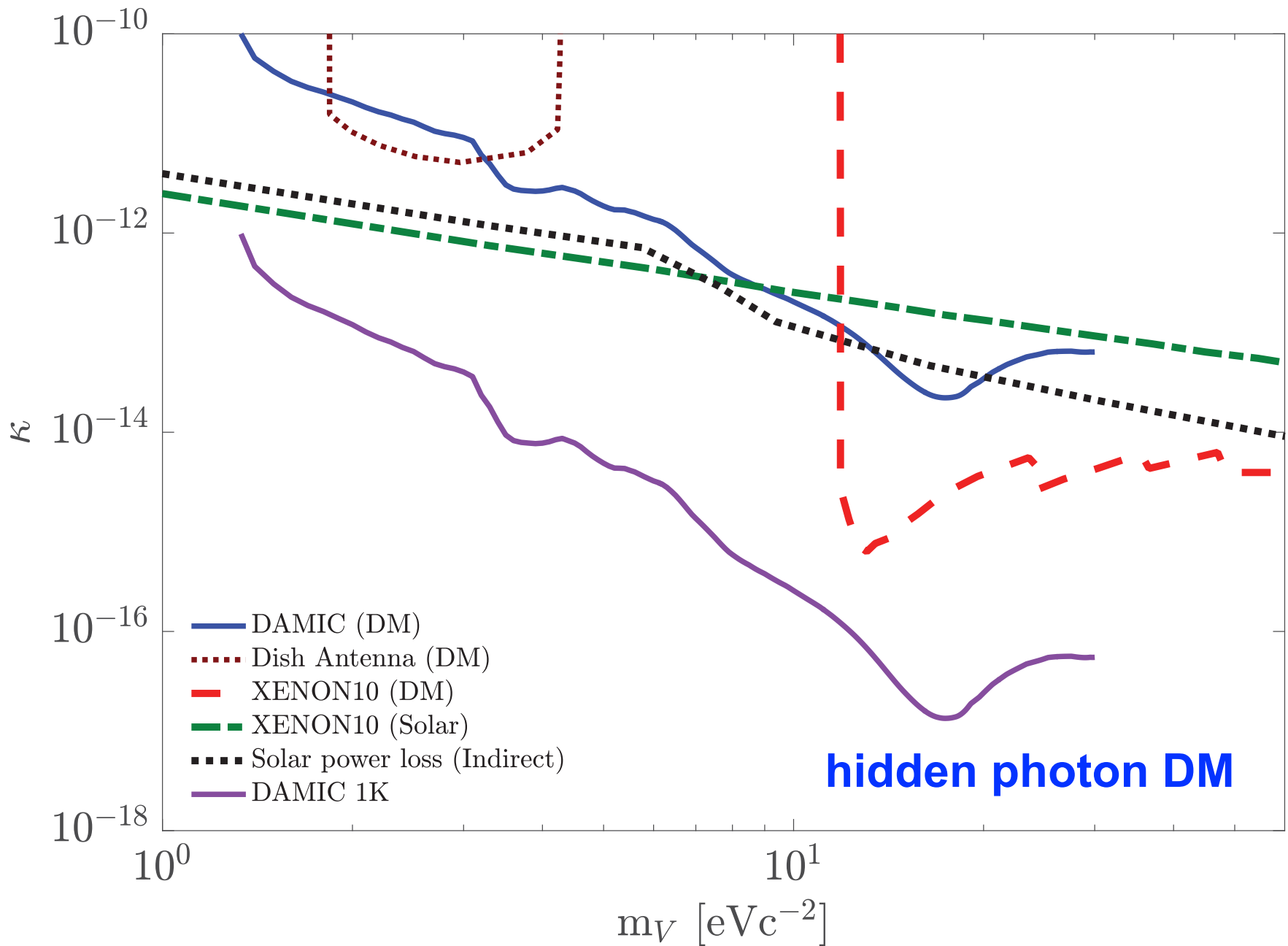

DAMIC-1K technical challenges

- A kg-size DAMIC can be built with the existing technology

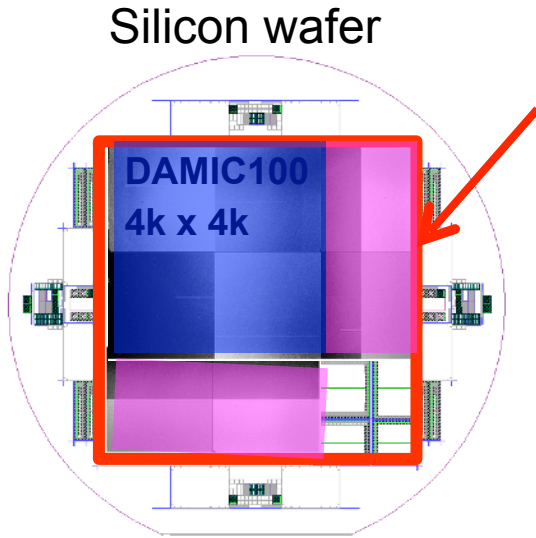

6k x 6k pixels, 1 mm thick

≈ 20 g / CCD

≈ 50 CCDs / 1 Kg

DALSA has confirmed the feasibility fabrication of these larger and thicker CCDs

- **Background**

from a few dru to a fraction of dru.

external bkg.: improved design, materials (e.g. electroformed copper), strict procedures (silicon storage underground, radon, surface contamination)

internal bkg.: cosmogenic ^{32}Si (in the atmosphere) and tritium (in the silicon)



DAMIC-1K background

- Cosmogenic ^{32}Si rate has been measured by DAMIC to be 80/kg/day and will be accurately measured by DAMIC100

JINST 10 P08014

$^{32}\text{Si} - ^{32}\text{P}$ candidate

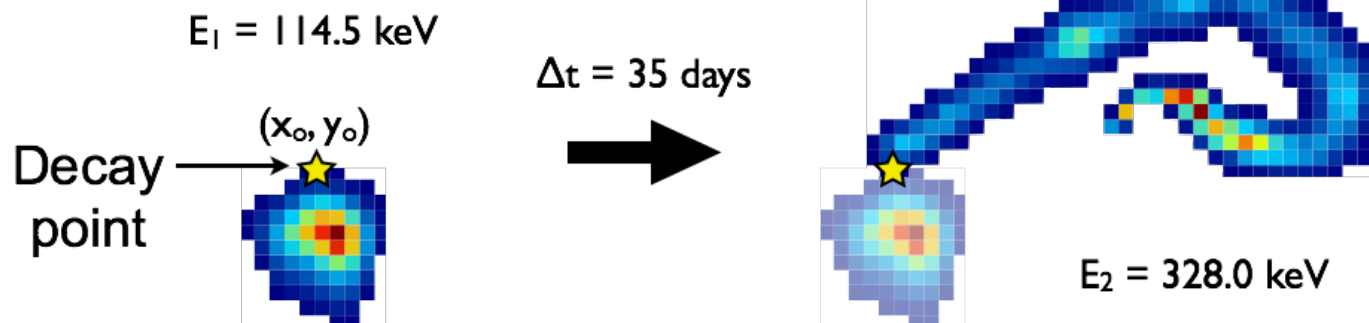

≈ 1 dru (dominant bkg. in SuperCDMS); **rejected in DAMIC-1K by spatial correlations**

- Cosmogenic tritium expected to be the dominant bkg. for DAMIC-1K.

A measurement of its rate may be within reach of the current DAMIC detector at SNOLAB (so far only estimates are used for forecasts)

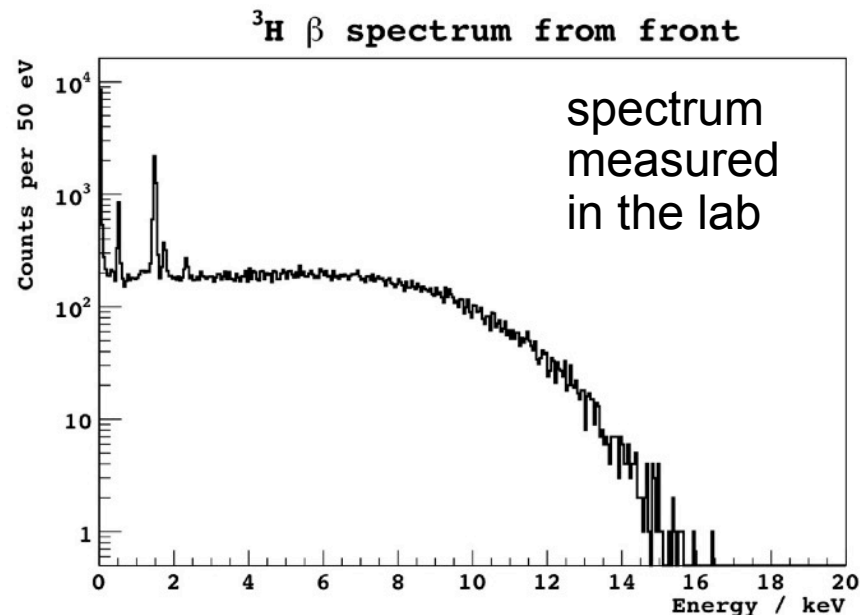

≈

DAMIC-1K sub-e⁻ noise

- Readout noise

After Correlated Double Sampling the noise is dominated by 1/f noise in the CCD amplifier

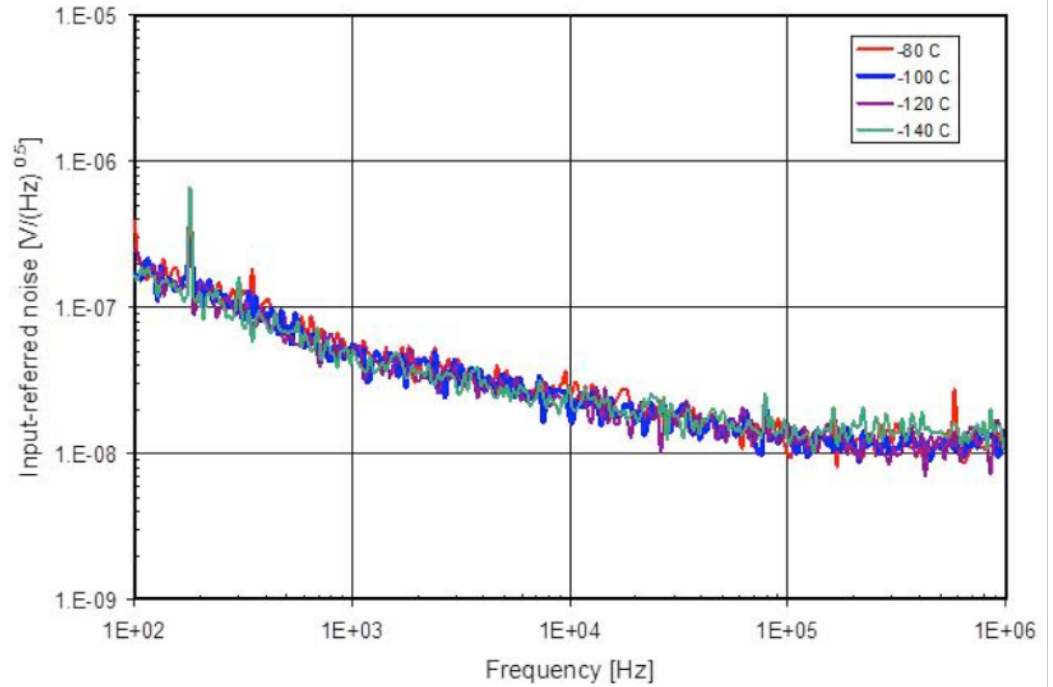

- CDS transfer function

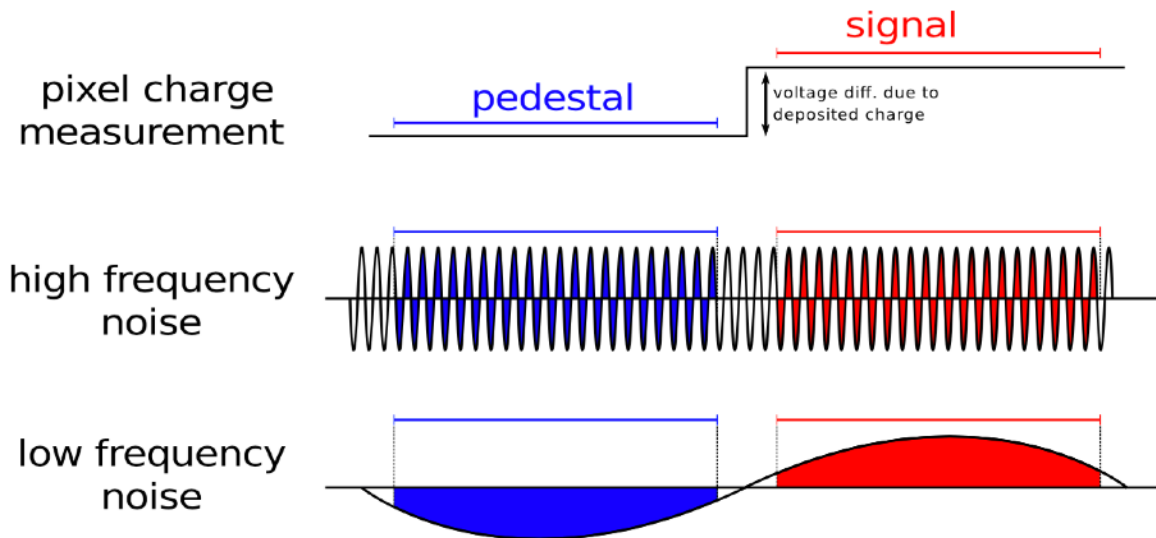
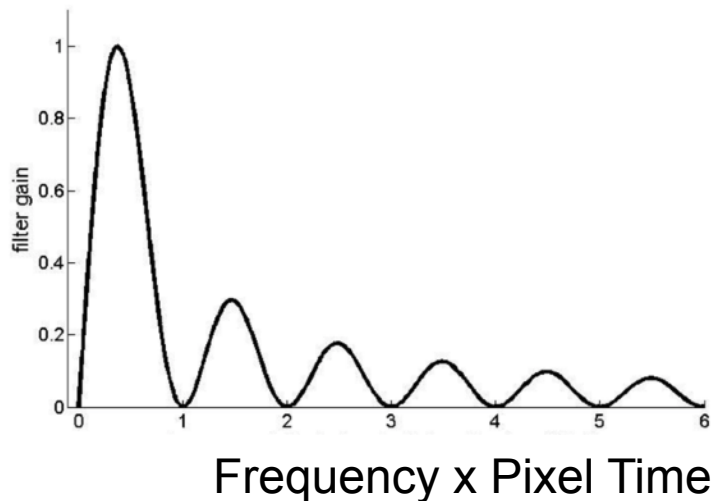

DAMIC-1K sub- e^- noise

- Skipper readout

Non-destructive measurement of the charge!

Measure the charge fast (kill $1/f$ noise) and N times (noise $\approx 1/\sqrt{N}$)

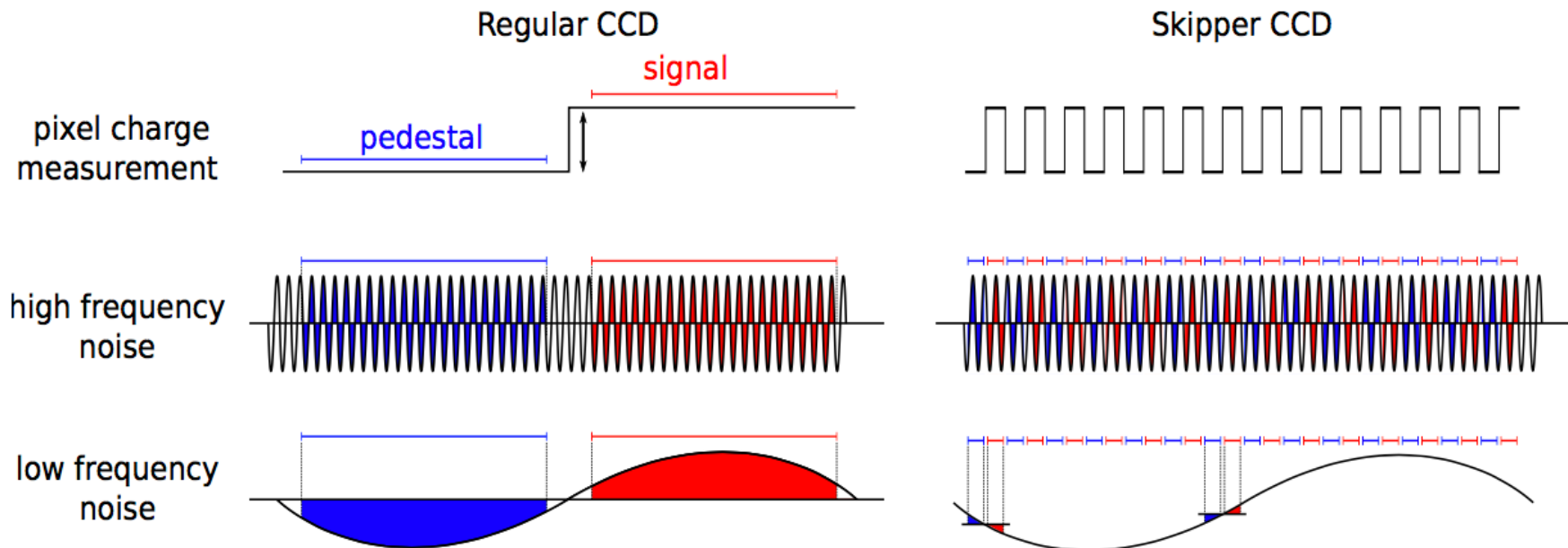
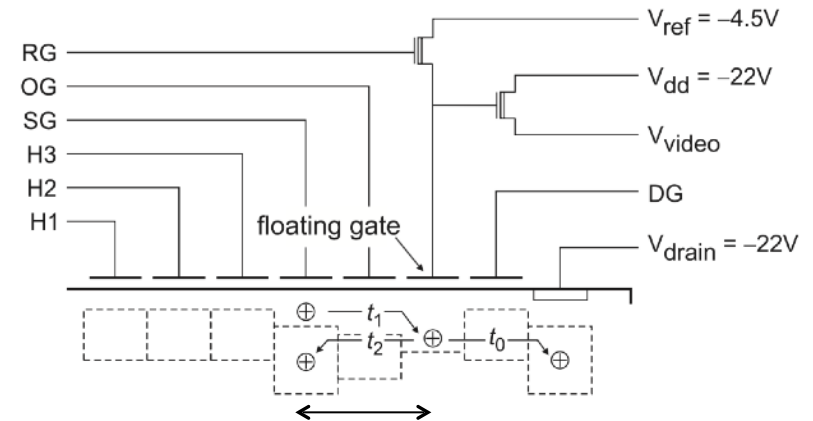

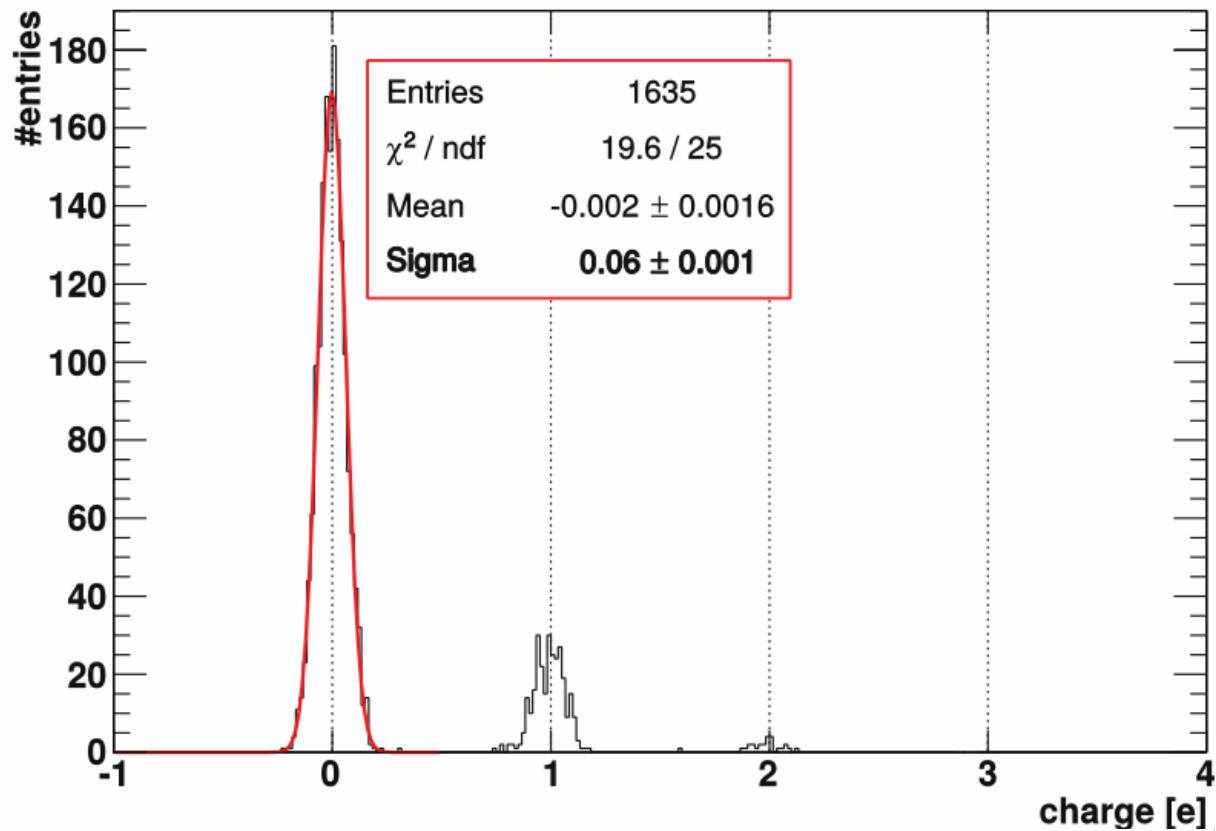

Skipper unprecedented sensitivity demonstrated on a small size DAMIC CCD (Fermilab)

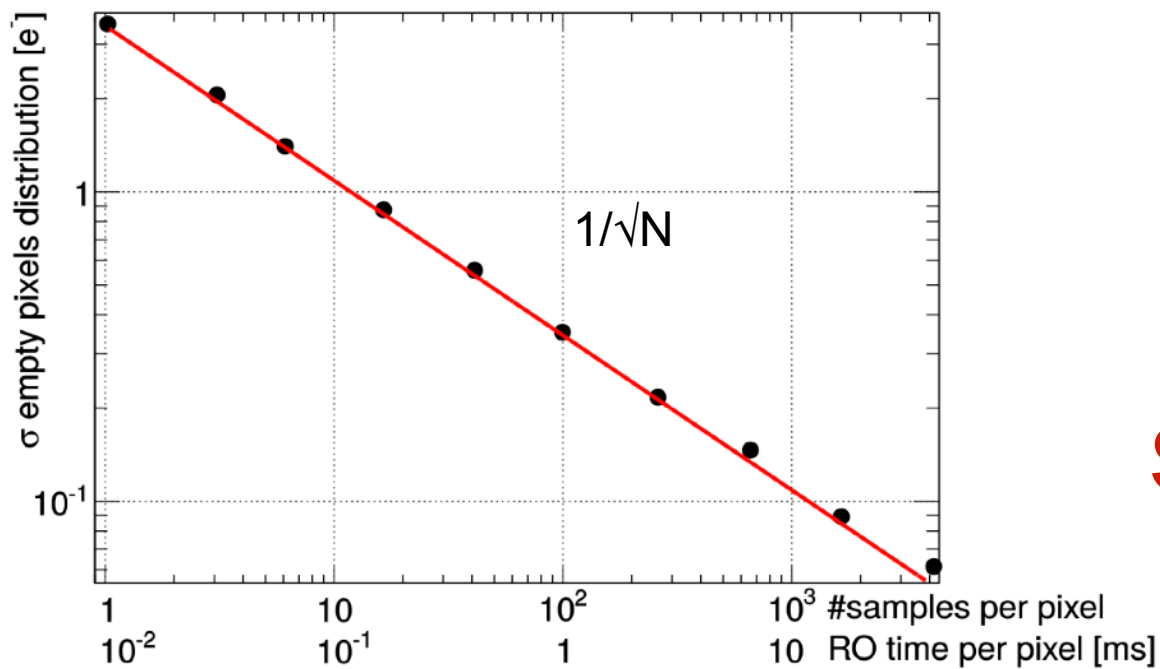

DAMIC-1K
sub- e^- noise

Potential applications and ongoing R&D

- Nuclear forensics

the analysis of nuclear materials recovered from either the capture of unused materials, or from the radioactive debris following a nuclear explosion, to identify of the sources of the materials and the industrial processes used to obtain them.



Our CCDs can provide:

- fast identification of hot particles in swipes
(for subsequent analysis)

- non-destructive analysis through gamma, beta and alpha spectroscopy

- Identification of a single nuclide

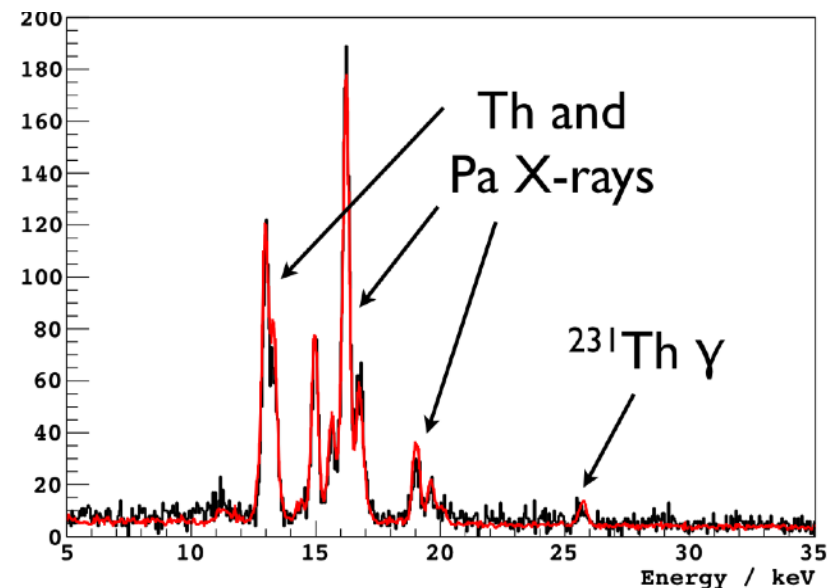

- Soft Error Rate (SER)

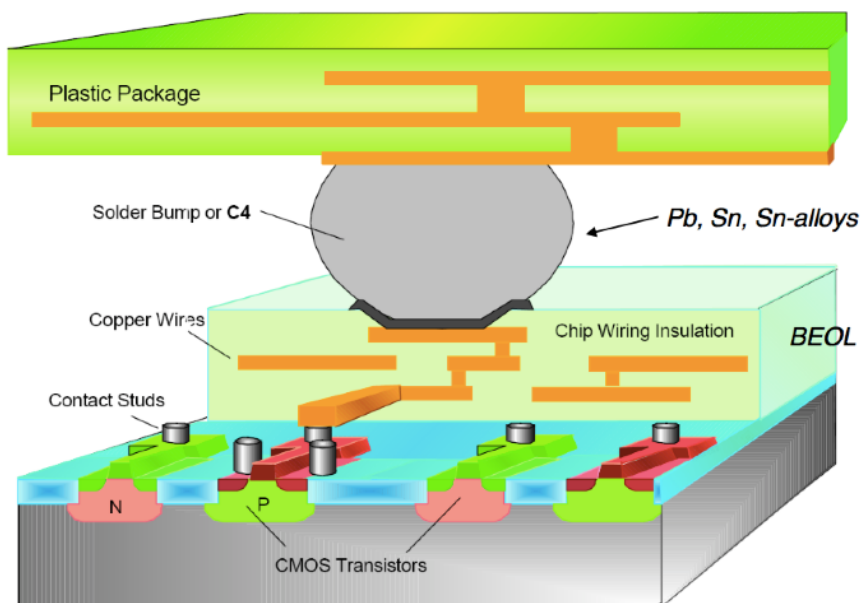

Errors in computer chips (memory & logic) that do not cause permanent damage

Induced by passage of energetic ionizing radiation through the sensitive volume of chips

Can be a major reliability problem in servers, laptops, smart phones, pacemakers, electronics

Alpha particles from chip packaging (ceramic, underfill, interconnects, contamination)

More and more important with scaling of technology (shrinking dimensions)

Reliable measurements of ultra-low alpha emissivity required

We have measured emissivity of many materials (e.g. copper, silicon, ancient lead, kapton, epoxy, etc.) down to **0.2 α / (khr cm²)** with properties unique to our CCDs: capability to locate the origin of the emission; alpha identification even with degraded energy; detection of beta and gamma in addition to alpha particles

Conclusions

- In the last two years DAMIC has established the CCD technology as a competitive technique for the search of low-mass Dark Matter particles
- DAMIC-1K, a kg-size CCD detector with low background and sub-electron noise, will explore a new large parameter space, scrutinizing the WIMPs paradigm, as well as dark sector candidates with sensitivity comparable to accelerator searches
- The DAMIC-1K detector is an incremental step of proven technologies (larger size CCD, sub-electron noise). It will work as specified.
- DAMIC-1K possible locations: SNOLAB (Canada), **Modane (France)**, SURF (USA), Gran Sasso Laboratory (Italy)
- The CCD technology developed for DAMIC has wider applications: coherent neutrino scattering, nuclear forensics, soft errors